

**SAER**<sup>®</sup>  
ELETTROPOMPE

serie  
**OP**

**Elettropompe  
multistadio orizzontali**  
*Horizontal multistage  
electric pumps*

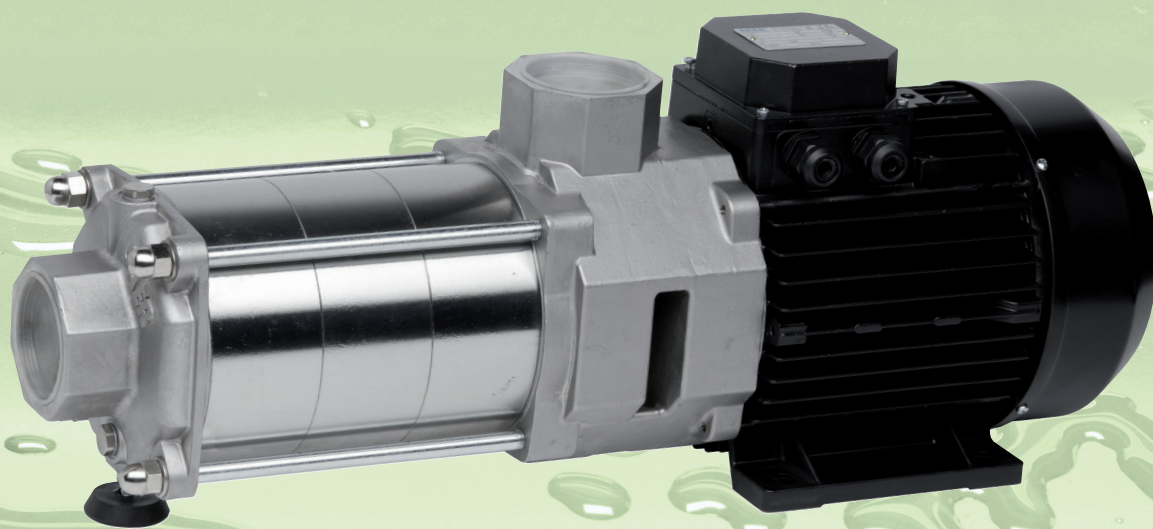



**ELETTROPOMPE CENTRIFUGHE MULTISTADIO ORIZZONTALI OP**

I

**IMPIEGHI**

Pompaggio di acqua pulita e liquidi chimicamente non aggressivi, impieghi domestici, distribuzione automatizzata di acqua in serbatoi medio piccoli, giardinaggio, irrigazione, approvvigionamento idrico. Inoltre, le pompe serie OP, grazie all'elevata prevalenza, possono essere utilizzate come pompe pilota in gruppi di pressurizzazione.

**DATI CARATTERISTICI**

Modelli suddivisi in due famiglie, con potenze da 0,37 a 13,5 kW  
 Qmax: 40 m<sup>3</sup>/h (50 Hz) / 48 m<sup>3</sup>/h (60 Hz)  
 Hmax: 126 m (50 Hz) / 120 m (60 Hz)  
 H (Q=0): 132 m (50 Hz) / 126 m (60 Hz)  
 Temperatura liquido pompato: min 0°C - max 90°C  
 Temperatura ambiente: max 40°C  
 Pressione massima d'esercizio (massima pressione ammissibile considerando la somma della pressione massima in aspirazione e della prevalenza a portata nulla): 13 bar (OP65:16 bar) con temperatura del liquido pompato fino a 45°C, 6 bar con temperatura del liquido pompato tra 45°C e 90°C

**CARATTERISTICHE COSTRUTTIVE**

Pompa centrifuga monoblocco multistadio orizzontale, non autodescante.  
 Corpo di mandata: ghisa EN-GJL250  
 Bocca di aspirazione: ghisa EN-GJL250  
 Corpo di stadio con diffusore: acciaio inossidabile AISI304 - acciaio al carbonio (OP50 - OP65)  
 Girante: acciaio inossidabile AISI304 - acciaio al carbonio (OP50 - OP65)  
 Tenuta meccanica: Ossido di Allumina-Grafite-EPDM  
 Albero rotore: acciaio inossidabile AISI 431  
 Motore  
 Classe di isolamento: F  
 Grado di protezione: OP32: IP44 (IP 55 a richiesta) - OP40 - OP50 - OP65: IP55  
 Versioni trifase: 380-400V 50 Hz / 440-460V 60 Hz  
 Versioni monofase: 220-230V 50 Hz / 230V 60 Hz, protettore termico incorporato su richiesta.  
 Voltaggi diversi a richiesta.

**TOLLERANZE**

Pompa: UNI EN ISO 9906 - Appendice A  
 Motore: IEC 60034-1

**VERSIONI SPECIALI**

OP32 i - OP40 i: versione con inverter integrato a bordo motore  
 Versione OPX (AISI316)

**HORIZONTAL MULTISTAGE CENTRIFUGAL ELECTRIC PUMPS OP**

GB

**USES**

Supply of clean water and non-aggressive chemical liquids. OP pumps are suitable for domestic use, for water automatic distribution by using small-middle pressure tanks, for gardening, irrigation, water supply from wells. Furthermore, thanks to the high head, OP pumps can be used as pilot pump for pressurization units.

**CHARACTERISTIC DATA**

Models subdivided in two series, with power from 0,37 Kw up to 13,5 kW  
 Qmax: 40 m<sup>3</sup>/h (50 Hz) / 48 m<sup>3</sup>/h (60 Hz)  
 Hmax: 126 m (50 Hz) / 120 m (60 Hz)  
 H (Q=0): 132 m (50 Hz) / 126 m (60 Hz)  
 Temperature of pumped liquid: min 0°C - max 90°C  
 Ambient temperature: max 40°C  
 Max operation pressure (max allowed pressure in consideration of the sum of max. suction pressure and of the head with null flow rate): 13 bar (OP65:16 bar) with temperature of the pumped liquid up to 45°C, 6 bar with temperature of the pumped liquid from 45°C up to 90°C

**CONSTRUCTION CHARACTERISTICS**

Horizontal centrifugal multistage electric pump, non self-priming  
 Outlet: cast iron EN-GJL250  
 Inlet: cast iron EN-GJL250  
 Diffuser body: Stainless steel AISI304 - carbon steel (OP50 - OP65)  
 Impeller: stainless steel AISI304 - carbon steel (OP50 - OP65)  
 Mechanical seal: Alumina oxide-Graphite-EPDM  
 Rotor shaft: stainless steel AISI 431  
 Motor  
 Insulation class: F  
 Protection: OP32: IP44 (IP 55 on request) - OP40 - OP50 - OP65: IP55  
 Three-phase versions: 380-400V 50 Hz / 440-460V 60 Hz  
 Single phase version: 220-230V 50 Hz / 230V 60 Hz, thermally protected on request.  
 Different voltages upon request.

**TOLERANCES**

Pump: UNI EN ISO 9906 - Appendix A  
 Motor: IEC 60034-1

**SPECIAL VERSIONS**

OP32 i - OP40 i: Version with frequency converter  
 OPX Version (AISI316)

**ELECTROBOMBAS CENTRIFUGAS MULTIETAPAS HORIZONTALES OP**

E

**APLICACIONES**

Bombeo de agua limpia y líquidos químicamente no agresivos, aplicaciones domésticas, distribución automatizada de agua en tanques medio-pequeños, jardinería, riego, abastecimiento hídrico. Además gracias a la altura elevada, las bombas serie OP pueden ser utilizadas como bombas piloto en grupos de presurización.

**DATOS CARACTERÍSTICOS**

Modelos divididos en dos familias, con potencias de 0,37 a 13,5 kW  
 Qmax: 40 m<sup>3</sup>/h (50 Hz) / 48 m<sup>3</sup>/h (60 Hz)  
 Hmax: 126 m (50 Hz) / 120 m (60 Hz)  
 H (Q=0): 132 m (50 Hz) / 126 m (60 Hz)  
 Temperatura del líquido bombeado: min 0°C - max 90°C  
 Temperatura máxima ambiente: 40°C  
 Presión máxima de funcionamiento: (máxima presión admitida en consideración de la suma de la presión máxima en aspiración y de la carga hidrostática con caudal nulo): 13 bar (OP65:16 bar) con temperatura del líquido bombeado hasta 45°C, 6 bar con temperatura del líquido bombeado de 45°C hasta 90°C

**CARACTERÍSTICAS DE CONSTRUCCIÓN**

Bomba centrifuga monobloc multietapa horizontal, no autocebante.  
 Cuerpo de descarga: fundición gris GJL250  
 Boca de aspiración: fundición gris GJL250  
 Cuerpo de etapa con difusor: acero inoxidable AISI304 - acero (OP50 - OP65)  
 Impulsor: acero inoxidable AISI304 - acero (OP50 - OP65)  
 Cierre mecánico: Óxido de alumina-grafito-EPDM  
 Eje rotor: acero inoxidable AISI 431  
 Motor  
 Clase de aislamiento: F  
 Grado de protección: OP32: IP44 (IP 55 bajo demanda) - OP40 - OP50 - OP65: IP55  
 Versiones trifásicas: 380-400V 50 Hz / 440-460V 60 Hz  
 Versiones monofásicas: 220-230V 50 Hz / 230V 60 Hz, protector térmico incorporado a petición  
 Voltajes diferentes a petición

**TOLERANCIAS:**

Bomba: UNI EN ISO 9906 - Parrafo A  
 Motor: IEC 60034-1

**EJECUCIONES ESPECIALES**

OP32 i - OP40 i: Version con inverter integrado en el motor  
 Versiones OPX (AISI316)

**ELECTROPOMPES CENTRIFUGES MULTI-ETAGE HORIZONTALES OP****F****UTILISATIONS**

Pompaggio d'eau claire et liquides chimiquement non agressifs, usage domestique, distribution automatique de l'eau dans petits ou moyens réservoirs, jardinage, arrosage, approvisionnement hydrique. Les pompes OP, grâce à l'haute débit, peuvent être employées comme pompe pilote dans les groupes de relevage.

**DONNEES CARACTERISTIQUES**

Modèles dans deux familles, avec puissance de 0,37 à 13,5 kW  
 Qmax: 40 m<sup>3</sup>/h (50 Hz) / 48 m<sup>3</sup>/h (60 Hz)  
 Hmax: 126 m (50 Hz) / 120 m (60 Hz)  
 H (Q=0): 132 m (50 Hz) / 126 m (60 Hz)  
 Température du liquide pompé: min 0°C – max 90°C  
 Température max ambiante: 40°C  
 Pression max. d'emploi (pression max. admissible en considération de la somme de la pression max. en aspiration et de l'hauteur avec débit nul): 13 bar (OP65: 16 bar) avec température du liquide pompé until 45°C, 6 bar température du liquide de 45°C à 90°C.

**CARACTÉRISTIQUES DE FABRICATION**

Pompe centrifuge monobloc multi-étage horizontale, non auto-amorçante. Corps de refoulement: fonte EN-GJL250  
 Orifice d'aspiration: fonte EN-GJL250  
 Corps d'étage avec diffuseur: acier inoxydable AISI 304 - acier (OP50 - OP65)  
 Roue: acier inoxydable AISI 304 - acier (OP50 - OP65)  
 Garniture mécanique: Oxyde d'alumine-Graphite-EPDM  
 Arbre: acier inoxydable AISI 431  
 Moteur  
 Isolement: classe F  
 Protection: OP32: IP44 (IP 55 sur demande) - OP40 - OP50 - OP65: IP55  
 Versions triphasées: 380-400V 50 Hz / 440-460V 60 Hz  
 Versions monophasées: 220-230V 50 Hz / 230V 60 Hz, protection thermique sur demande.  
 Voltages spéciaux sur demande.

**TOLÉRANCES**

Pompe: UNI EN ISO 9906 Annexe A  
 Moteur: norme CEI 60034-1

**VERSIONS SPECIALES**

OP32 i - OP40 i: Version avec variateur de vitesse inclus  
 Version OPX (AISI316)

**MEHRSTUFIGE HORIZONTALE KREISELELEKTROPUMPEN****D****EINSATZBEREICHE**

Fördern vom Wasser und anderen chemisch unaggressiven Flüssigkeiten. Die Pumpe ist für den Einsatz im Hausbereich, für automatisierte Wasserdistribution in kleine oder mittelmässige Tanks bestimmt und kann auch in Gärten für die Bewässerung und im allgemeinen für die Wasserlieferung verwendet werden. Außerdem kann die Pumpe, dank der erhöhten Förderhöhe, als eine Steuerpumpe in einer Druckgruppe gebraucht werden.

**EIGENSCHAFTEN**

Modelle, die in zwei Typen verteilt sind, mit der Leistung von 0,37 bis 13,5 kW.  
 Qmax: 40 m<sup>3</sup>/h (50 Hz) / 48 m<sup>3</sup>/h (60 Hz)  
 Hmax: 126 m (50 Hz) / 120 m (60 Hz)  
 H (Q=0): 132 m (50 Hz) / 126 m (60 Hz)  
 Temperatur der Pumpenflüssigkeit: min 0°C – max 90°C  
 Temperatur der Umgebung: max 40°C  
 Maximaler Arbeitsdruck (maximaler zulässiger Druck, wobei man die Summe vom maximalen Saugdruck und von der Foerderhoehe bei der Null-Foerdermenge in Betracht nimmt): 13 bar (OP65: 16 bar), wenn Temperatur der gepumpten Flüssigkeit bis zum 45 ° C ist. 6 bar, wenn Temperatur der gepumpten Flüssigkeit von 45° C bis 90° C ist.

**BAUEIGENSCHAFTEN**

Mehrstufige horizontale einblockkreiselpumpe mit einigenLaurädern Druckstutzen: Gusseisen GJL250  
 Saugstutzen: Gusseisen GJL250  
 Stufeneinrichtung mit Diffusor: Edelstahl AISI304 - stahl (OP50 - OP65)  
 Lauftrad: Edelstahl AISI304 - stahl (OP50 - OP65)  
 Mechanische Dichtung: Aluminiumoxyd-Graphite-EPDM  
 Rotorwelle: Edelstahl AISI 431  
 Motor  
 Isolationsklasse: F  
 Schutz: OP32: IP44 (IP 55 Auf Wunsch) - OP40 - OP50 - OP65: IP55  
 Dreiphasige Ausführung: 380-400V 50 Hz / 440-460V 60 Hz  
 Einphasige Ausführung: 220-230V 50 Hz / 230V 60 Hz, Mit thermischem Schutz wenn gewünscht  
 Auf Wunsch verschiedene Spannungen

**TOLERANZEN**

Pumpe: UNI EN ISO 9906 – Anhang A  
 Motor: IEC 60034-1

**SONDERAUSFÜHRUNGEN**

OP32 i - OP40 i: Ausführung mit dem in den Motor eingebauten Frequenzrichter  
 Version OPX (AISI316)

**ELECTROBOMBAS CENTRIFUGAS MULTISTAGIO HORIZONTALES.****P****EMPREGOS**

Bombeio de agua limpa e líquidos quimicamente não agressivos, empregos caseiros, distribuição automatizada de água em reservatórios meio pequenos, jardinagem, irrigação, abastecimento hídrico. Além disso, as bombas série OP, devido a alta pressão, podem ser empregadas como bomba piloto em grupos de pressurização.

**ELEMENTOS CARACTERISTICOS**

Modelos subdivididos em duas familia, com potencia de 0,37 ate 13,5 kW  
 Qmax: 40 m<sup>3</sup>/h (50 Hz) / 48 m<sup>3</sup>/h (60 Hz)  
 Hmax: 126 m (50 Hz) / 120 m (60 Hz)  
 H (Q=0): 132 m (50 Hz) / 126 m (60 Hz)  
 Temperatura do líquido bombeado: min 0°C – max 90°C  
 Temperatura ambiente: max 40°C  
 Pressao maxima de trabalho (maxima pressao admitible considerando as soma de la pressao maxima em aspiração e de la pressao a caudal zero): 13 bar (OP65: 16 bar) com temperatura do líquido bombeado ate os 45°C, 6 bar com temperatura do líquido bombeado entre 45°C e 90°C

**CARACTERISTICAS DE CONSTRUCAO**

Bomba centrifuga monobloc multiestagio horizontal, no autoescorbante. Corpo de saida: Ferro-coado EN-GJL250  
 Boca de aspiração: Ferro-coado EN-GJL250  
 Corpo do estagio com diffusor: aço inox AISI304 - aço (OP50 - OP65)  
 Turbina: aço inox AISI304 - aço (OP50 - OP65)  
 Vedacao mecanica: Oxido de Alumina-Gráfite-EPDM  
 Veio rotor: aço inox AISI 431  
 Motor  
 Classe de isolamento: F  
 Grado de protecao: OP32: IP44 (IP 55 com requerimento) - OP40 - OP50 - OP65: IP55  
 Versoes trifasico: 380-400V 50 Hz / 440-460V 60 Hz  
 Versoes monofasico: 220-230V 50 Hz / 230V 60 Hz, protecao termica incorporada com requerimento  
 Voltagem especiais com requerimento

**TOLERANCIAS**

Bomba: UNI EN ISO 9906 – apendice A  
 Motor: IEC 60034-1

**VERSÃO ESPECIAIS**

OP32 i - OP40 i: Versao com inverter integrado no motor  
 Versão OPX (AISI316)

**Серия OP - Горизонтальные центробежные насосы с несколькими рабочими колёсами****RUS****Применение**

Перекачивание чистой воды и химически неагрессивных жидкостей в частном хозяйстве. Автоматическая подача в маленькие и средние емкости для садоводства при орошении. Кроме того, серия OP, благодаря своим напорным характеристикам может быть использована как головной насос в составе АНС.

**Характеристики**

Различных моделей подразделяются на две подгруппы мощностью от 0,37 до 13,5 кВт  
 Qmax: 40 м<sup>3</sup>/ч (50 Гц) / 48 м<sup>3</sup>/ч (60 Гц)  
 Hmax: 126 м (50 Гц) / 120 м (60 Гц)  
 H (Q=0): 132 м (50 Гц) / 126 м (60 Гц)  
 Температура перекачиваемой жидкости: мин. 0 °С – макс. 90 °С  
 Температура окружающей среды: макс. 40 °С  
 Максимальное рабочее давление (максимально допустимое давление, принимая во внимание сумму максимального давления на всасывании и подачи при нулевом напоре 13 бар (OP65: 16 бар) при температуре перекачиваемой жидкости до 45°C, 6 бар при температуре перекачиваемой жидкости до 90°C

**Конструкция**

Центробежный нормальновсасывающий моноблочный насос с горизонтальной установкой.  
 Напорный патрубок: чугун GJL250  
 Всасывающий патрубок: чугун GJL250  
 Сектор кожуха с диффузором: нержавеющая сталь AISI304 - сталь (OP50 - OP65)  
 Рабочее колесо: нержавеющая сталь AISI304 - сталь (OP50 - OP65)  
 Торцевое уплотнение: оксид алюминия – графит – EPDM  
 Вал ротора: нержавеющая сталь AISI 431  
 Двигатель  
 Изоляция: F  
 Степень защиты: OP32: IP44 (IP 55 по запросу) - OP40 - OP50 - OP65: IP55  
 Трёхфазное исполнение: 380-400V 50 Гц / 440-460V 60 Гц  
 Однофазное исполнение: 220-230V 50 Гц / 230V 60 Гц термозащита по запросу.  
 Другое напряжение-по запросу.

**Соответствия**

Насос: UNI EN ISO – Дополнение A  
 Двигатель: IEC 60034-1

**ИСПОЛНЕНИЯ**

OP32 i - OP40 i: Исполнение с инвертером встроенным в двигатель  
 Исполнение OPX (AISI316)

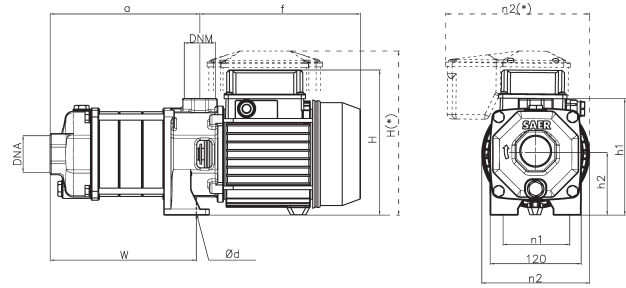
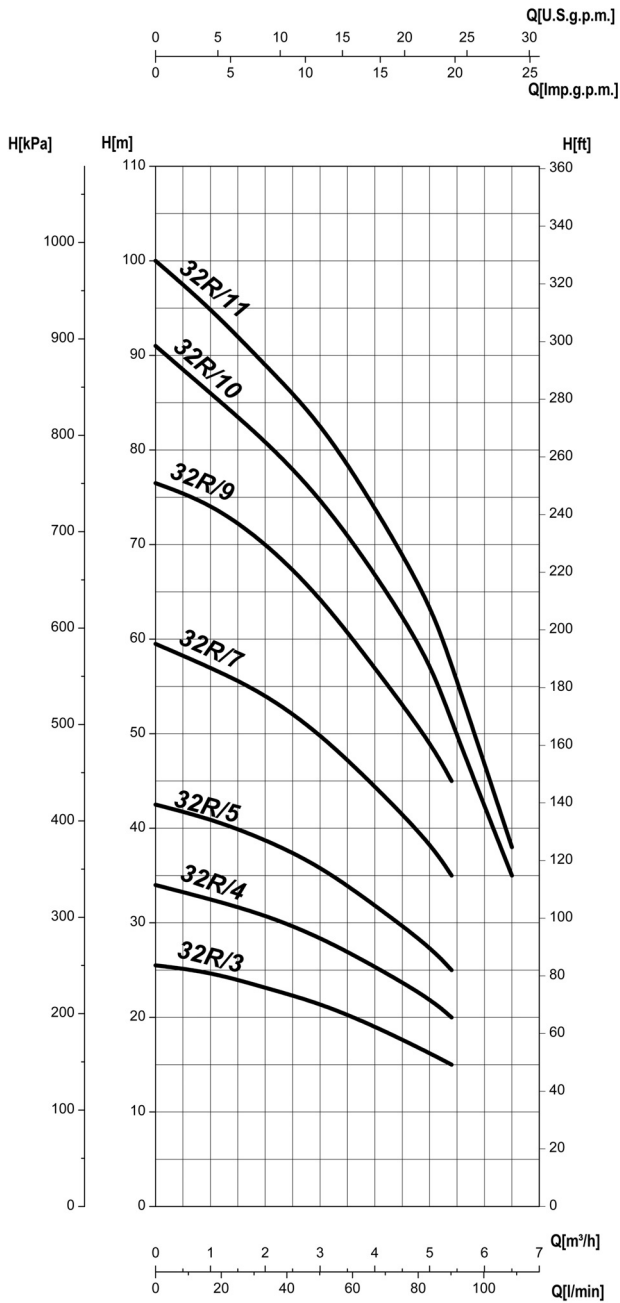

OP	a (mm)	f (mm)	w (mm)	H (mm)	Ød (mm)	h1 (mm)	h2 (mm)	n1 (mm)	n2 (mm)	DNA	DNM
32R/3	191	210	187,5	190	11	153	80	84	142	1"1/4	1"
32R/4	221	210	218	190	11	153	80	84	142	1"1/4	1"
32R/5	252	233	248,5	190	11	153	80	84	142	1"1/4	1"
32R/7	313	245	309,5	210	11	163	90	90	160	1"1/4	1"
32R/9	373	283	366,5	210	11	163	90	90	160	1"1/4	1"
32R/10	404	283	397,5	210	11	163	90	90	160	1"1/4	1"
32R/11	435	283	428	210	11	163	90	90	160	1"1/4	1"

OP	P <sub>2</sub>		P <sub>1</sub>	230V 1~		400V 3~ In
	kW	HP		In (A)	C 450 Vc (µF)	
32R/3	0,55	0,75	0,9	4	16	2
32R/4	0,75	1	1,2	5,8	20	2,6
32R/5	0,9	1,2	1,4	6,2	25	3,1
32R/7	1,1	1,5	1,6	8,5	31,5	3,5
32R/9	1,5	2	2,1	10,7	40	4,5
32R/10	1,5	2	2,3	11,5	40	4,7
32R/11	2,2	3	2,4	13,7	50	4,8

• CARATTERISTICHE IDRAULICHE • HYDRAULIC FEATURES • CARACTERISTICAS HIDRAULICAS • CARACTERISTIQUES HYDRAULIQUES  
• HYDRAULISCHE EIGENSCHAFTEN • CARACTERÍSTICAS HIDRÁULICAS • ГИДРАВЛИЧЕСКИЕ ХАРАКТЕРИСТИКИ

OP	P <sub>2</sub>		U.S.g.p.m.	0	4,5	9	13	18	22	24	28,5
	kW	HP									
50 Hz	Q		m³/h	0	1	2	3	4	5	5,4	6,5
	Q		l/min	0	17	33	50	67	83	90	108
32R/3	0,55	0,75	H (m)	25,5	25	23	21,5	19	16	15	
32R/4	0,75	1		34	32,5	30,5	28,5	25	22	20	
32R/5	0,9	1,2		42,5	41	39	36	32	27,5	25	
32R/7	1,1	1,5		59,5	57	54	50	44,5	38,5	35	
32R/9	1,5	2		76,5	75	70	64,5	57	49	45	
32R/10	1,5	2		91	86	81	75	67	58	51	35
32R/11	2,2	3		100	95	89	83	74	65	57	38

UNI EN ISO 9906-A

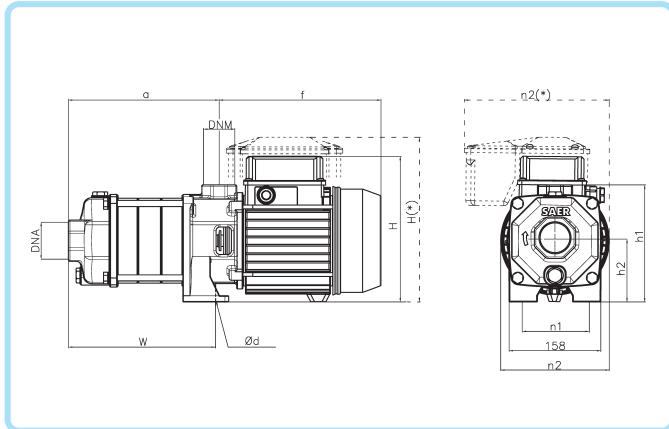

OP	a (mm)	f (mm)	w (mm)	H (mm)	Ød (mm)	h1 (mm)	h2 (mm)	n1 (mm)	n2 (mm)	DNA	DNM
32/2	160,5	210	157	190	11	153	80	87	142	1"1/4	1"
32/3	191	210	187,5	190	11	153	80	87	142	1"1/4	1"
32/4	221,5	210	218	190	11	153	80	87	142	1"1/4	1"
32/5	252	233	248,5	212(*)	11	153	80	87	190(*)	1"1/4	1"
32/6	282,5	238	275,5	200	11	170	80	87	160	1"1/4	1"
32/8	343,5	283	336,5	210	11	163	90	90	160	1"1/4	1"
32/10	404,5	283	397,5	237(*)	11	163	90	90	207(*)	1"1/4	1"
32/11	435	283	428	237(*)	11	163	90	90	207(*)	1"1/4	1"

OP 50 Hz	P <sub>2</sub>		P <sub>1</sub>	230V 1~		400V 3~
	kW	HP	kW	In	C	In
				(A)	450 Vc (µF)	
32/2	0,37	0,5	0,70	3,5	12,5	1,5
32/3	0,55	0,75	0,90	4	16	2
32/4	0,75	1	1,20	5,8	20	2,6
32/5	0,9	1,2	1,40	6,2	25	3,1
32/6	1,1	1,5	1,70	8,5	31,5	3,5
32/8	1,5	2	2,1	10,3	40	4,1
32/10	2,2	3	2,4	13,7	50	4,8
32/11	2,2	3	2,7	14,5	50	5,1

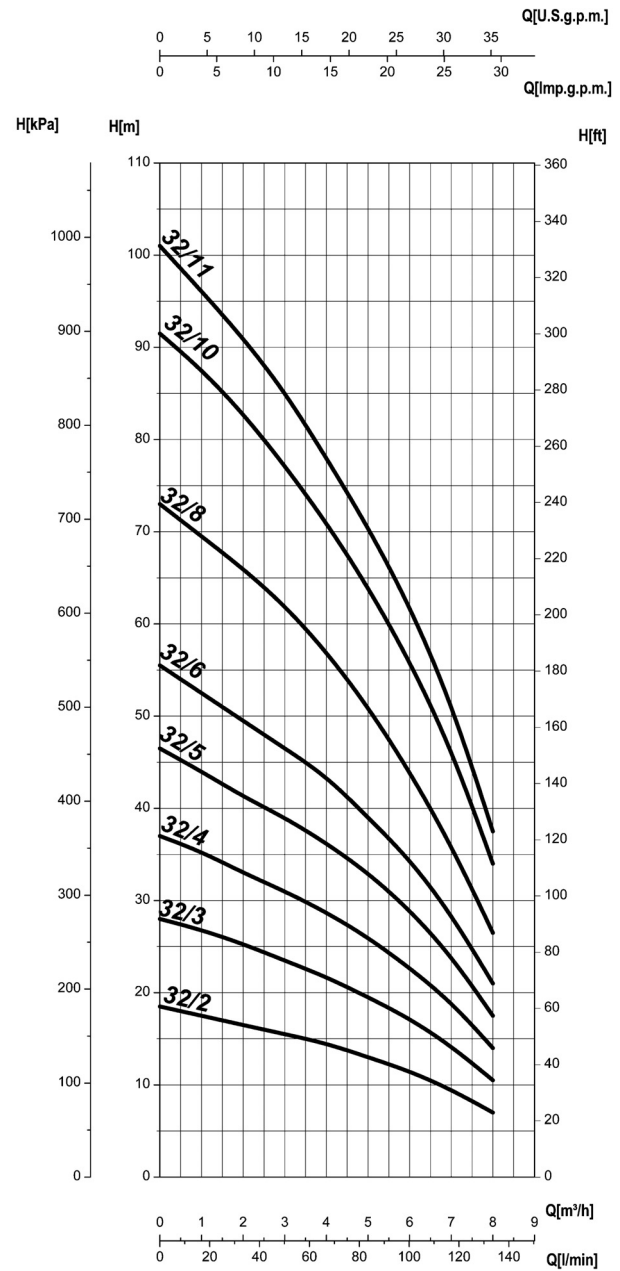

• CARATTERISTICHE IDRAULICHE • HYDRAULIC FEATURES • CARACTERISTICAS HIDRAULICAS • CARACTERISTIQUES HYDRAULIQUES  
• HYDRAULISCHE EIGENSCHAFTEN • CARACTERÍSTICAS HIDRÁULICAS • ГИДРАВЛИЧЕСКИЕ ХАРАКТЕРИСТИКИ

OP 50 Hz	P <sub>2</sub>		U.S.g.p.m.	Q									
	kW	HP		0	4,5	9	13	18	22	26,5	31	35,5	
				m³/h	0	1	2	3	4	5	6	7	8
			l/min	0	17	33	50	67	83	100	117	133	
			H (m)	18,5	17,5	16,5	15,5	14,5	13	11,5	9,5	7	
32/2	0,37	0,5		28	26,5	25	23,5	22	19,5	17,5	14,5	10,5	
32/3	0,55	0,75		37	35	33	31	29	26	23	19	14	
32/4	0,75	1		46,5	44	41	39	36,5	33	29	24	17,5	
32/5	0,9	1,2		55,5	52,5	49,5	46,5	43,5	39	34,5	28,5	21	
32/6	1,1	1,5		73	69,5	66	62	57	51	44	36	26,5	
32/8	1,5	2		91,5	87,5	83	77	71	64	56	46,5	34	
32/10	2,2	3		101	96	91	85	78	70,5	62	51,5	37,5	
32/11	2,2	3											

UNI EN ISO 9906-A

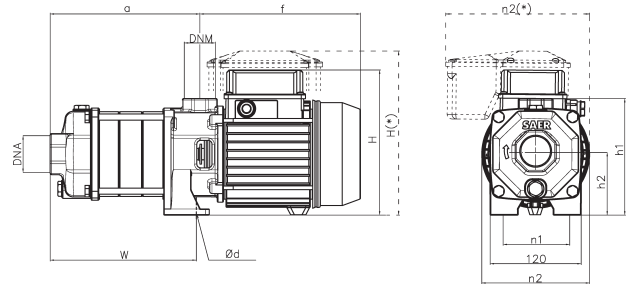
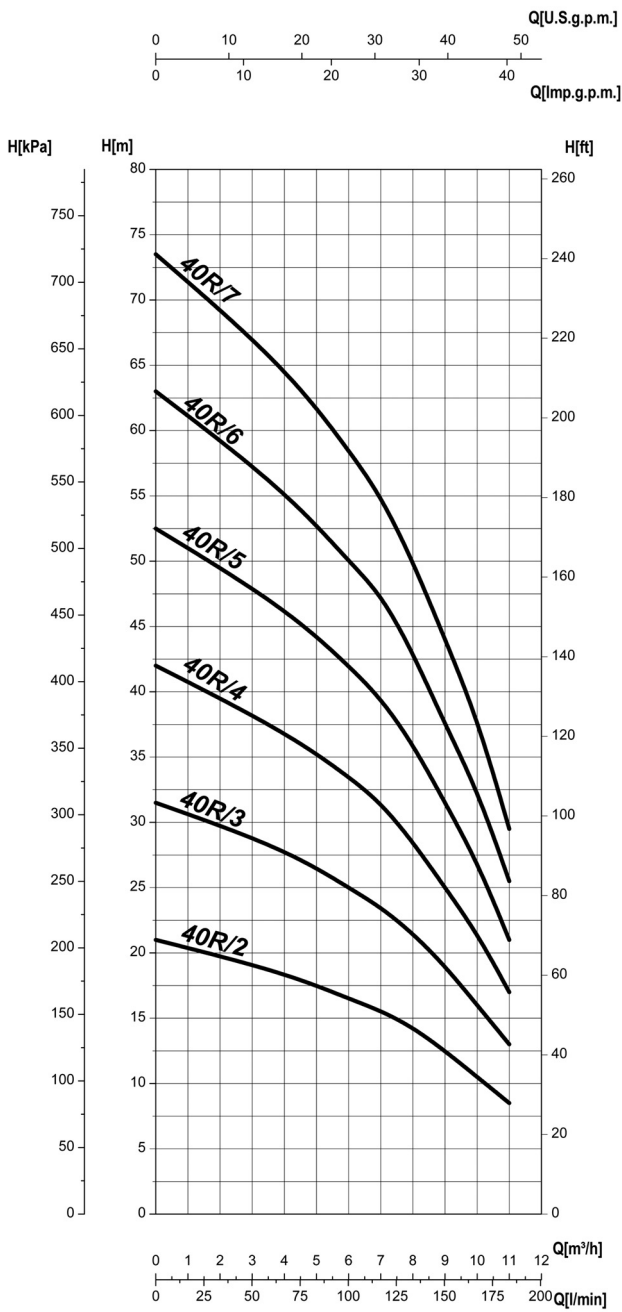

OP	a (mm)	f (mm)	w (mm)	H (mm)	Ød (mm)	h1 (mm)	h2 (mm)	n1 (mm)	n2 (mm)	DNA	DNM
40R/2	181	260	196,5	220	11	202	100	113	160	1"1/2	1"1/2
40R/3	213	260	228,5	220	11	202	100	113	160	1"1/2	1"1/2
40R/4	245	260	260,5	220	11	202	100	113	160	1"1/2	1"1/2
40R/5	277	260	292,5	220	11	202	100	113	160	1"1/2	1"1/2
40R/6	309	297	324,5	220	11	202	100	113	160	1"1/2	1"1/2
40R/7	341	297	356,5	247*	11	202	100	113	207*	1"1/2	1"1/2

OP	P <sub>2</sub>		P <sub>1</sub>	230V 1~		400V 3~
	kW	HP	kW	I <sub>n</sub> (A)	C 450 Vc (µF)	I <sub>n</sub> (A)
40R/2	0,75	1	1,2	5,8	25	2,6
40R/3	1,1	1,5	1,5	8,5	31,5	3,2
40R/4	1,5	2	2,0	10,1	40	3,9
40R/5	1,5	2	2,3	10,3	40	4,1
40R/6	2,2	3	2,6	10,8	50	4,8
40R/7	2,2	3	3	13,7	50	5,2

• CARATTERISTICHE IDRAULICHE • HYDRAULIC FEATURES • CARACTERISTICAS HIDRAULICAS • CARACTERISTIQUES HYDRAULIQUES  
• HYDRAULISCHE EIGENSCHAFTEN • CARACTERÍSTICAS HIDRÁULICAS • ГИДРАВЛИЧЕСКИЕ ХАРАКТЕРИСТИКИ

OP	P <sub>2</sub>		G	H (m)								
	kW	HP		U.S.g.p.m.	0	18	26,5	31	35,5	40	44	48,5
50 Hz			m³/h	0	4	6	7	8	9	10	11	
			l/min	0	66,7	100	117	133	150	167	183	
40R/2	0,75	1	H (m)	21	18,5	16,5	15,5	14	12,5	10,5	8,5	
40R/3	1,1	1,5		31,5	28	25	23,5	21,5	19	16	13	
40R/4	1,5	2		42	37	33,5	31,5	28,5	25	21,5	17	
40R/5	1,5	2		52,5	46,5	42	39,5	36	31,5	27	21	
40R/6	2,2	3		63	55,5	50	47,5	43	37,5	32,5	25,5	
40R/7	2,2	3		73,5	65	58,5	55	50	44	38	29,5	

UNI EN ISO 9906-A

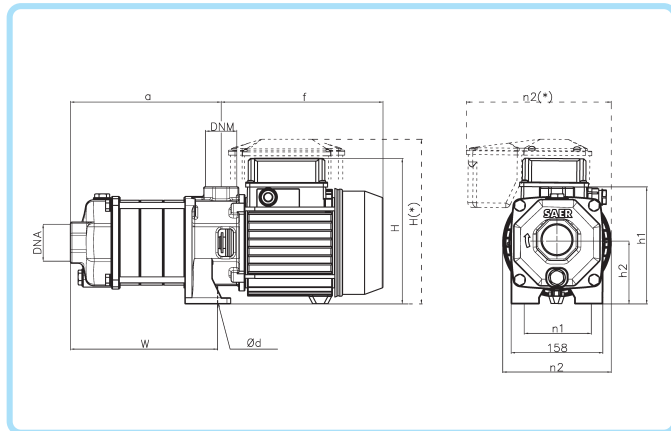

OP	a (mm)	f (mm)	w (mm)	H (mm)	Ød (mm)	h1 (mm)	h2 (mm)	n1 (mm)	n2 (mm)	DNA	DNM
40/2	181	260	196,5	220	11	202	100	115	160	1 1/2	1 1/2
40/3	213	260	228,5	220	11	202	100	115	160	1 1/2	1 1/2
40/4	245	260	260,5	220	11	202	100	115	160	1 1/2	1 1/2
40/5	277	297	292,5	247(*)	11	202	100	115	207(*)	1 1/2	1 1/2
40/6	309	297	324,5	247(*)	11	202	100	115	207(*)	1 1/2	1 1/2

OP 50 Hz	P <sub>2</sub>		P <sub>1</sub> kW	230V 1~		400V 3~ In (A)
	kW	HP		In (A)	C 450 Vc (µF)	
40/2	0,75	1	1,1	5,5	25	2,4
40/3	1,1	1,5	1,5	8,5	31,5	3,2
40/4	1,5	2	2,0	10,1	40	3,9
40/5	2,2	3	2,5	14,0	50	4,8
40/6	2,2	3	2,9	15,2	50	5,2

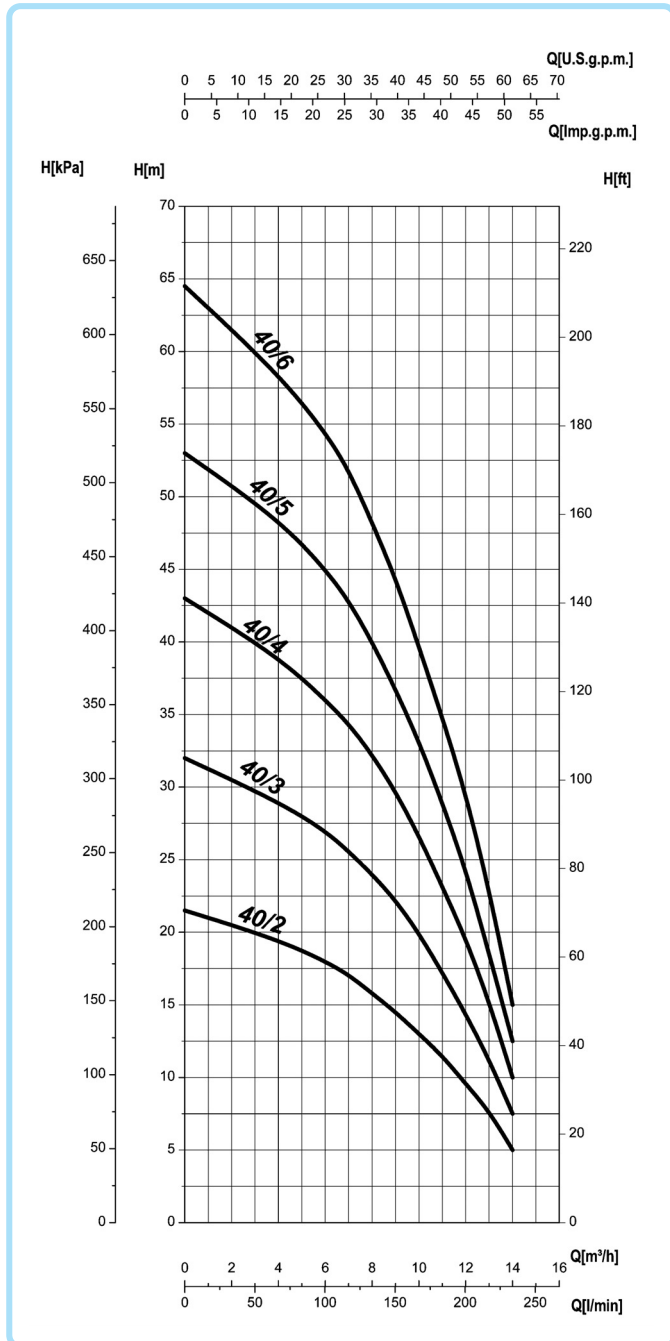

• CARATTERISTICHE IDRAULICHE • HYDRAULIC FEATURES • CARACTERISTICAS HIDRAULICAS • CARACTERISTIQUES HYDRAULIQUES  
• HYDRAULISCHE EIGENSCHAFTEN • CARACTERÍSTICAS HIDRÁULICAS • ГИДРАВЛИЧЕСКИЕ ХАРАКТЕРИСТИКИ

OP 50 Hz	P <sub>2</sub>		Q	H (m)											
	kW	HP		U.S.g.p.m.	0	18	26,5	31	35,5	40	44	48,5	53	57,5	62
			m <sup>3</sup> /h	0	4	6	7	8	9	10	11	12	13	14	
			l/min	0	67	100	117	133	150	167	183	200	217	233	
40/2	0,75	1		21,5	19,5	18	17,5	16	14,5	13	11,5	10	7,5	5	
40/3	1,1	1,5		32	29	27	26	24	22	19,5	17	15	11	7,5	
40/4	1,5	2		43	39	36	35	32	29,5	26	22,5	20	15	10	
40/5	2,2	3		53	48,5	45	43,5	40	36,5	32,5	28,5	25	18,5	12,5	
40/6	2,2	3		64,5	58,5	54	52,5	48	44	39	33,5	30	22,5	15	

UNI EN ISO 9906-A

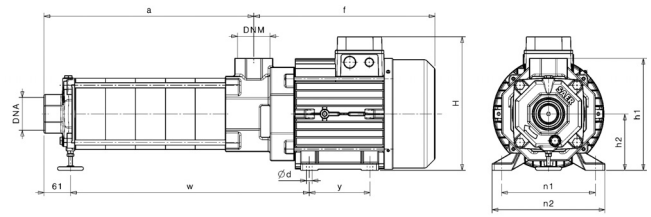
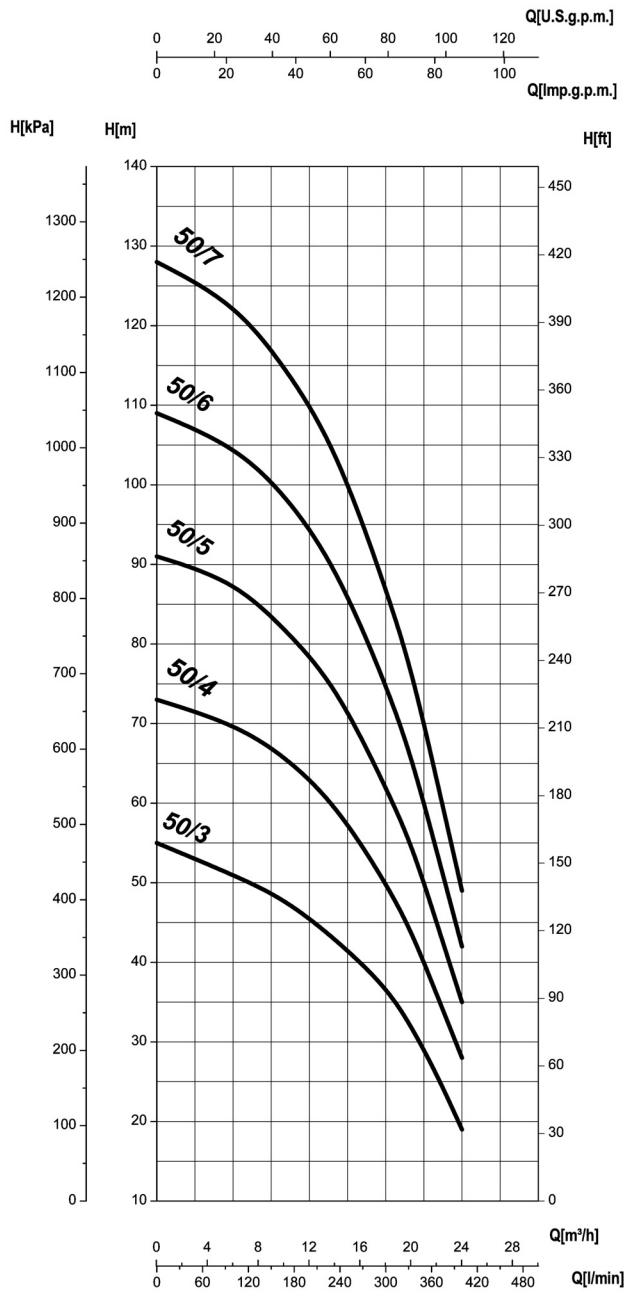

OP	a (mm)	f (mm)	w (mm)	H (mm)	Ød (mm)	h1 (mm)	h2 (mm)	n1 (mm)	n2 (mm)	y (mm)	DNA	DN1
50/3	290	315	350	210	10	206	90	140	175	125	2"	2"
50/4	345	370	415	262	13	250	112	190	220	140	2"	2"
50/5	400	370	470	262	13	250	112	190	220	140	2"	2"
50/6	455	370	525	262	13	250	112	190	220	140	2"	2"
50/7	510	370	580	262	13	250	112	190	220	140	2"	2"

OP	P2		P1	400V 3~ In
	kW	HP	kW	A
50/3	3	4	3,6	8,1
50/4	4	5,5	5,3	8,5
50/5	5,5	7,5	6,5	10,2
50/6	5,5	7,5	6,5	13,6
50/7	7,5	10	8,9	14,1

• CARATTERISTICHE IDRAULICHE • HYDRAULIC FEATURES • CARACTERISTICAS HIDRAULICAS • CARACTERISTIQUES HYDRAULIQUES  
• HYDRAULISCHE EIGENSCHAFTEN • CARACTERÍSTICAS HIDRÁULICAS • ГИДРАВЛИЧЕСКИЕ ХАРАКТЕРИСТИКИ

OP	P <sub>2</sub>		G	H (m)								
	kW	HP		U.S.g.p.m.	0	26	44	61	79	88	97	106
50 Hz			m³/h	0	6	10	14	18	20	22	24	
			l/min	0	100	167	233	300	333	367	400	
50/3	3	4		55	52	49	44	37	32	27	19	
50/4	4	5,5		73	70	66	60	50	44	36	28	
50/5	5,5	7,5		91	88	82	75	62	55	45	35	
50/6	5,5	7,5		109	105	99	90	75	66	54	42	
50/7	7,5	10		128	123	116	105	87	77	63	49	

UNI EN ISO 9906-A



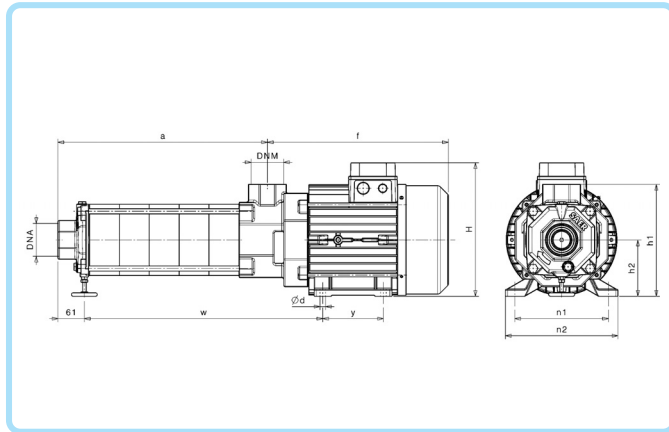

OP	a (mm)	f (mm)	w (mm)	H (mm)	Ød (mm)	h1 (mm)	h2 (mm)	n1 (mm)	n2 (mm)	y (mm)	DNA	DNm
65/2	270	370	318	262	13	250	112	190	220	140	2"1/2	2"1/2
65/3	339	370	387	262	13	250	112	190	220	140	2"1/2	2"1/2
65/4	408	370	456	262	13	250	112	190	220	140	2"1/2	2"1/2
65/5	484	420	551	310	13	260	132	216	260	140	2"1/2	2"1/2
65/6	553	420	620	310	13	260	132	216	260	140	2"1/2	2"1/2

OP	P2		P1	400V 3~ In
	kW	HP		
50 Hz				A
65/2	4	5,5	4,8	8,3
65/3	5,5	7,5	6,5	11,4
65/4	7,5	10	8,9	15,2
65/5	9,2	12,5	10,6	18
65/6	11	15	12,7	20,5

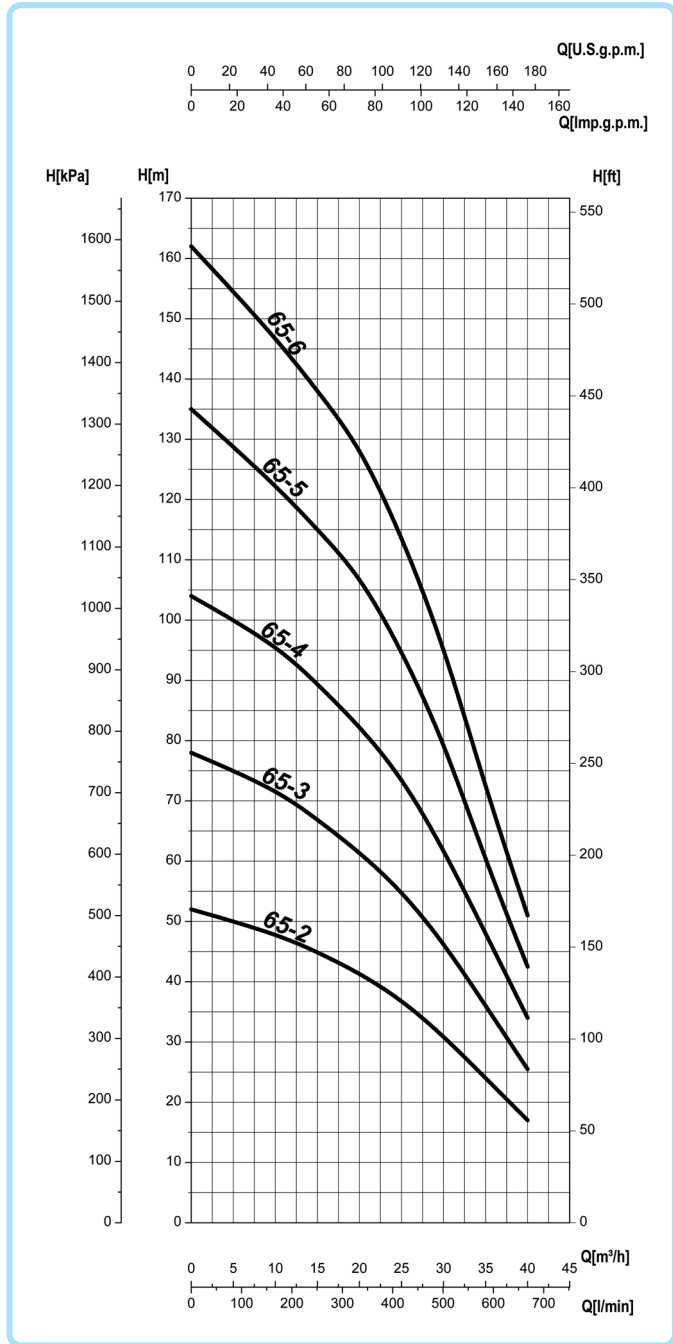

**• CARATTERISTICHE IDRAULICHE • HYDRAULIC FEATURES • CARACTERISTICAS HIDRAULICAS • CARACTERISTIQUES HYDRAULIQUES  
• HYDRAULISCHE EIGENSCHAFTEN • CARACTERÍSTICAS HIDRÁULICAS • ГИДРАВЛИЧЕСКИЕ ХАРАКТЕРИСТИКИ**

OP	P <sub>e</sub>		Q	H (m)								
				0	44	66	88	110	132	154	176	
	50 Hz	kW		HP	0	10	15	20	25	30	35	40
			U.S.g.p.m.	0	44	66	88	110	132	154	176	
			m <sup>3</sup> /h	0	10	15	20	25	30	35	40	
			l/min	0	167	250	333	417	500	583	667	
65/2	4	5,5	H (m)	52	48	45	42	37	31	24	17	
65/3	5,5	7,5		78	72	67	62	55	47	36	26	
65/4	7,5	10		104	96	90	83	74	62	48	34	
65/5	9,2	12,5		135	123	115	108	95	80	60	43	
65/6	11	15		162	147	138	129	114	96	72	51	

UNI EN ISO 9906-A

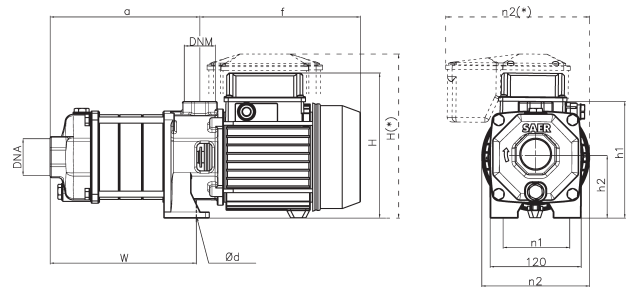
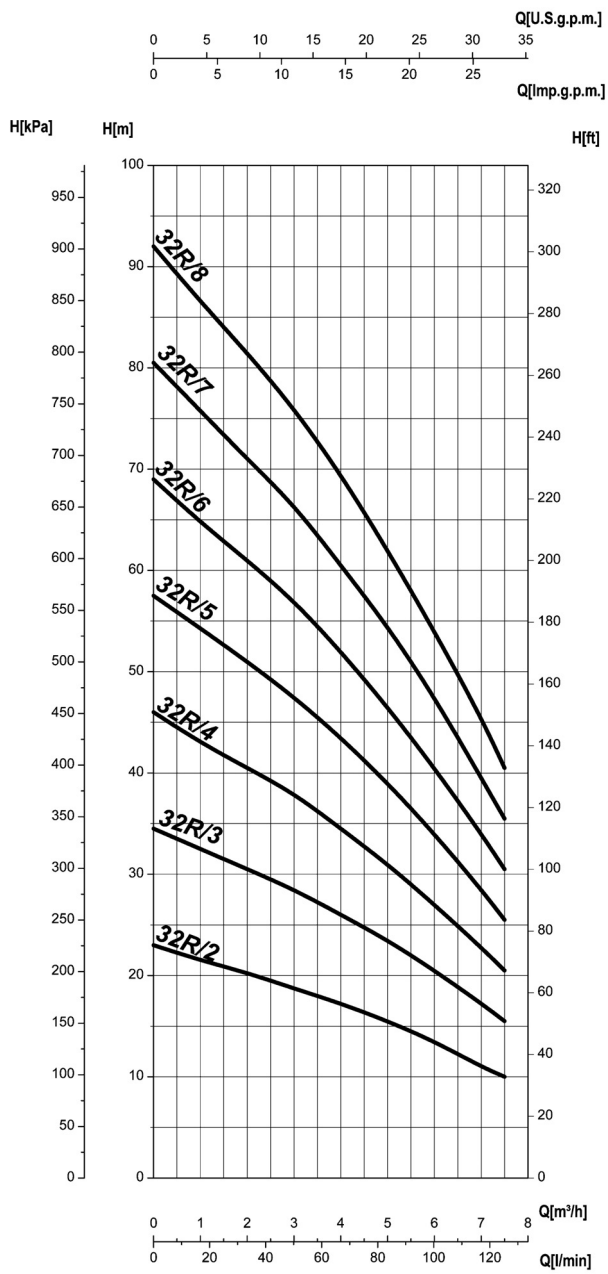

60P	a (mm)	f (mm)	w (mm)	H (mm)	Ød (mm)	h1 (mm)	h2 (mm)	n1 (mm)	n2 (mm)	DNa	DNm
32R/2	160,5	208	157	190	11	153	80	84	142	1 1/4"	1"
32R/3	191	238	187,5	190	11	153	80	84	160	1 1/4"	1"
32R/4	221,5	238	218	210	11	163	90	90	160	1 1/4"	1"
32R/5	252	238	248,5	210	11	163	90	90	160	1 1/4"	1"
32R/6	282,5	238	279	210	11	163	90	90	160	1 1/4"	1"
32R/7	313	283	309,5	237*	11	163	90	90	207*	1 1/4"	1"
32R/8	343,5	283	340	237*	11	163	90	90	207*	1 1/4"	1"

60P	P <sub>2</sub>		P <sub>1</sub>	230V 1~		460V 3~ In
	kW	HP		In (A)	C 450 Vc (µF)	
60 Hz						
32R/2	0,55	0,75	0,8	3,9	16	1,8
32R/3	0,75	1	1,2	5,8	20	2,3
32R/4	1,1	1,5	1,6	8,5	31,5	3,1
32R/5	1,5	2	1,9	10	40	3,9
32R/6	1,5	2	2,3	11,5	40	4,3
32R/7	2,2	3	2,6	14,2	50	4,5
32R/8	2,2	3	3,1	15,8	50	5,1

• CARATTERISTICHE IDRAULICHE • HYDRAULIC FEATURES • CARACTERISTICAS HIDRAULICAS • CARACTERISTIQUES HYDRAULIQUES  
• HYDRAULISCHE EIGENSCHAFTEN • CARACTERÍSTICAS HIDRÁULICAS • ГИДРАВЛИЧЕСКИЕ ХАРАКТЕРИСТИКИ

60P	P <sub>2</sub>		U.S.g.p.m.	0	4,4	8,8	13,2	17,6	22	26,4	30,8	33
	kW	HP	Q	m³/h	0	1	2	3	4	5	6	7
60 Hz					l/min	0	1,36	33,3	50	66,7	83,5	100
32R/2	0,55	0,75	H (m)	23	21,5	20	19	17	15,5	13,5	11	10
32R/3	0,75	1		34,5	32,5	30,5	28,5	26	23,5	20,5	17	15,5
32R/4	1,1	1,5		46	43	40,5	38	34,5	31	27	23	20,5
32R/5	1,5	2		57,5	54	51	47,5	43,5	39	34	28,5	25,5
32R/6	1,5	2		69	65	61	57	52	46,5	40,5	34	30,5
32R/7	2,2	3		80,5	76	71	66,5	60,5	54,5	47,5	39,5	35,5
32R/8	2,2	3		92	86,5	81,5	76	69,5	62	54	45,5	40,5

UNI EN ISO 9906-A

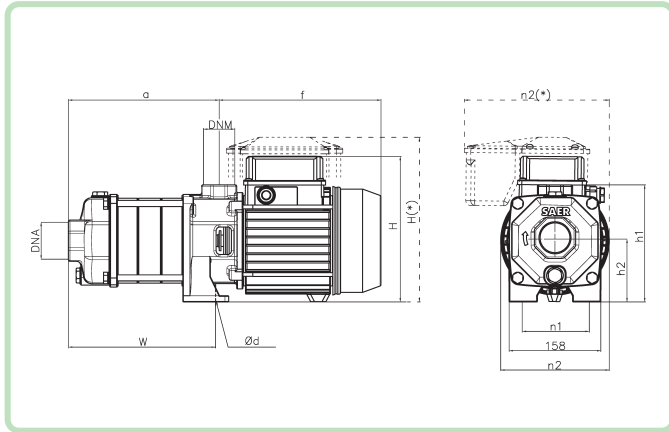

60P	a	f	w	H	Ød	h1	h2	n1	n2	DNA	DNM
	(mm)	(mm)	(mm)	(mm)	(mm)	(mm)	(mm)	(mm)	(mm)		
32/2	160,5	208	157	190	11	153	80	84	142	1"1/4	1"
32/3	191	233	187,5	190	11	153	80	84	142	1"1/4	1"
32/4	221,5	238	218	210	11	163	90	90	160	1"1/4	1"
32/5	252	238	248,5	237	11	163	90	90	207*	1"1/4	1"
32/6	282,5	283	279	237	11	163	90	90	207*	1"1/4	1"

60P	P <sub>2</sub>		P <sub>1</sub>	230V 1~		460V 3~
	60 Hz	60 Hz		In	C	
	kW	HP	kW	(A)	450 Vc (µF)	(A)
32/2	0,75	1	1,1	5,5	20	2,2
32/3	0,9	1,2	1,4	6,2	25	2,7
32/4	1,1	1,5	1,6	8,5	31,5	3,1
32/5	1,5	2	2,2	11,4	40	4,2
32/6	2,2	3	3,1	15,8	50	5,1

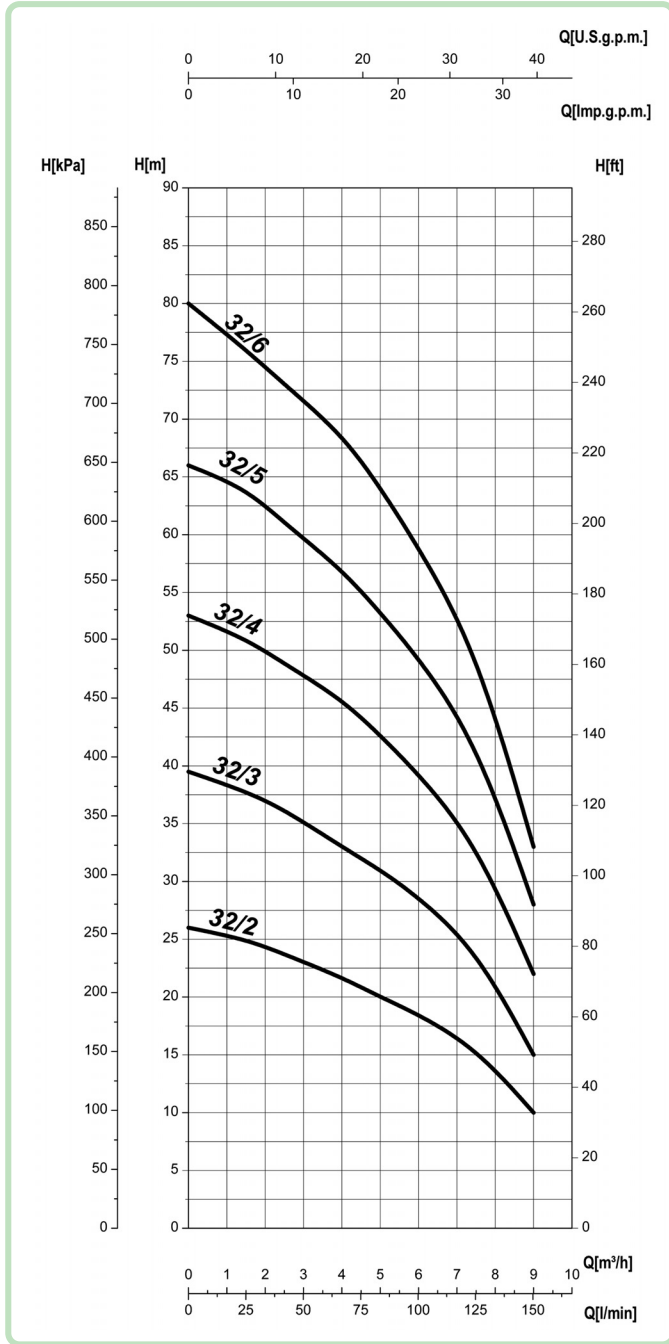

• CARATTERISTICHE IDRAULICHE • HYDRAULIC FEATURES • CARACTERISTICAS HIDRAULICAS • CARACTERISTIQUES HYDRAULIQUES  
• HYDRAULISCHE EIGENSCHAFTEN • CARACTERÍSTICAS HIDRÁULICAS • ГИДРАВЛИЧЕСКИЕ ХАРАКТЕРИСТИКИ

60P	P <sub>2</sub>		Q	H (m)							
	60 Hz	60 Hz		U.S.g.p.m.	0	6,5	11	18	22	26,5	33
			m³/h	0	1,5	2,5	4	5	6	7,5	9
			l/min	0	25	42	67	83	100	125	150
32/2	0,75	1		26	25	23,5	21,5	20	18,5	15,5	10
32/3	0,9	1,2		39,5	38	36	33	31	28,5	24	15
32/4	1,1	1,5		53	51	49	45,5	42,5	39	33,5	22
32/5	1,5	2		66	64	61	57	53	49	42	28
32/6	2,2	3		80	76	73	69	64	59	50	33

UNI EN ISO 9906-A

# 60P40/R

60 Hz

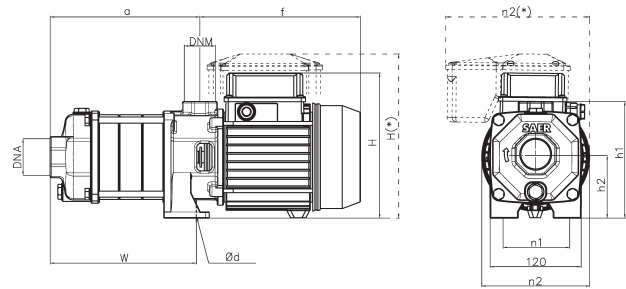
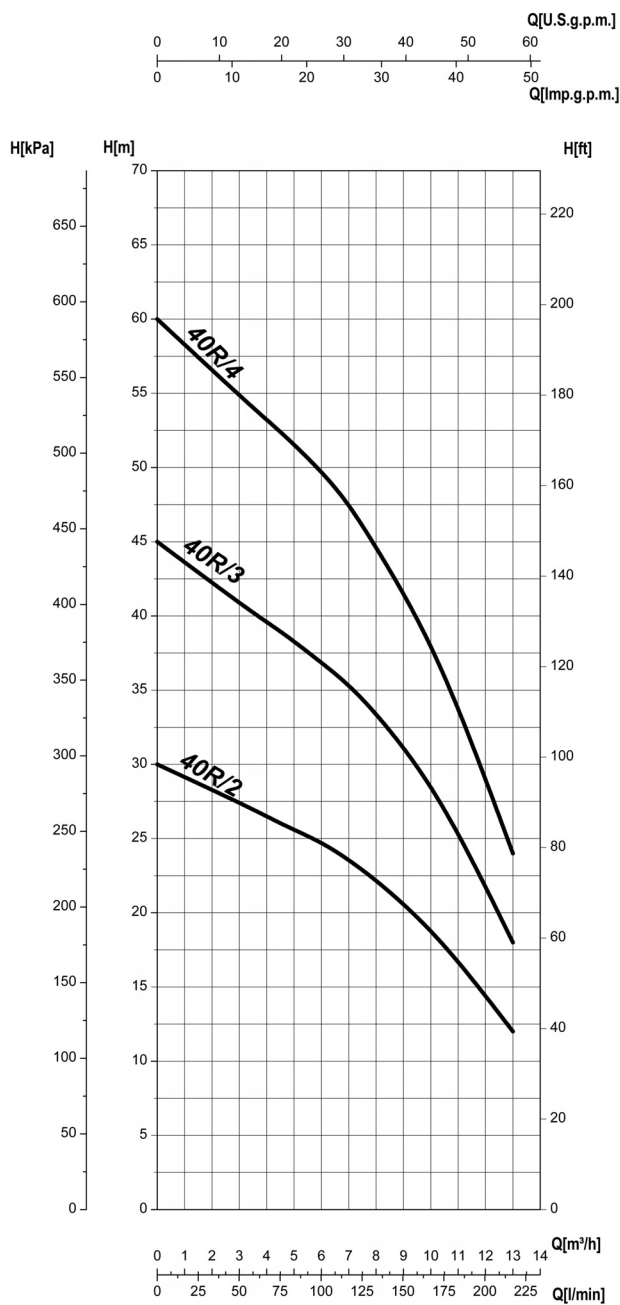

60P	a (mm)	f (mm)	w (mm)	H (mm)	Ød (mm)	h1 (mm)	h2 (mm)	n1 (mm)	n2 (mm)	DNA	DNM
40R/2	181	260	196,5	220	11	202	100	113	160	1"1/2	1"1/2
40R/3	213	260	228,5	220	11	202	100	113	160	1"1/2	1"1/2
40R/4	245	297	260,5	220	11	202	100	113	160	1"1/2	1"1/2

60P	P <sub>2</sub>		P <sub>1</sub>	230V 1~		460V 3~
	kW	HP	kW	I <sub>n</sub> (A)	C 450 Vc (µF)	I <sub>n</sub> (A)
60 Hz						
40R/2	1,1	1,5	1,8	9,3	31,5	3,4
40R/3	1,5	2	2,5	12,7	40	4,8
40R/4	2,2	3	3,1	15,8	50	5,1

• CARATTERISTICHE IDRAULICHE • HYDRAULIC FEATURES • CARACTERISTICAS HIDRAULICAS • CARACTERISTIQUES HYDRAULIQUES  
• HYDRAULISCHE EIGENSCHAFTEN • CARACTERÍSTICAS HIDRÁULICAS • ГИДРАВЛИЧЕСКИЕ ХАРАКТЕРИСТИКИ

60P	P <sub>2</sub>		Q	U.S.g.p.m.	0	15	20	26,5	31	35,5	41,5	48,5	57
	kW	HP		m³/h	0	3,5	4,5	6	7	8	9,5	11	13
60 Hz			l/min	0	58	75	100	117	133	158	183	217	
40R/2	1,1	1,5	H (m)	30	27	26	24,5	23,5	22	20	17	12	
40R/3	1,5	2		45	40	39	37	35,5	33,5	30	25,5	18	
40R/4	2,2	3		60	54	52,5	50	47,5	44,5	40	34	24	

UNI EN ISO 9906-A

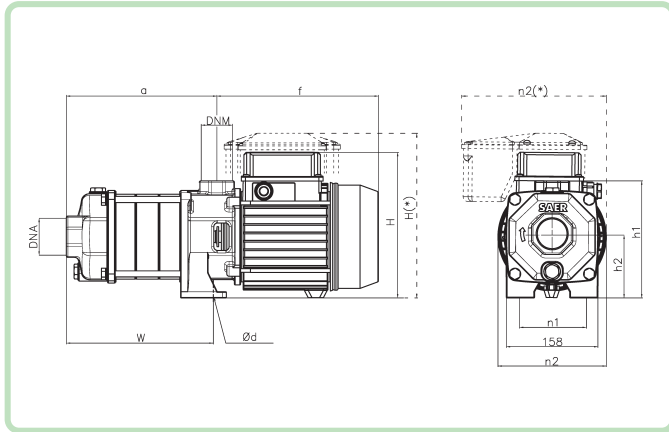

60P	a	f	w	H	Ød	h1	h2	n1	n2	DNA	DNM
	(mm)	(mm)	(mm)	(mm)	(mm)	(mm)	(mm)	(mm)	(mm)		
40/2	181	260	196,5	220	11	202	100	115	160	1 1/2	1 1/2
40/3	213	260	228,5	220	11	202	100	115	160	1 1/2	1 1/2
40/4	245	297	260,5	247(*)	11	202	100	115	207(*)	1 1/2	1 1/2

60P	P <sub>2</sub>		P <sub>1</sub>	230V 1~		460V 3~
	60 Hz			In	C	
	kW	HP	kW	(A)	450 Vc (µF)	(A)
40/2	1,1	1,5	1,6	9,0	31,5	3,1
40/3	1,5	2	2,4	12,5	40	5,0
40/4	2,2	3	3,1	16,0	50	5,2

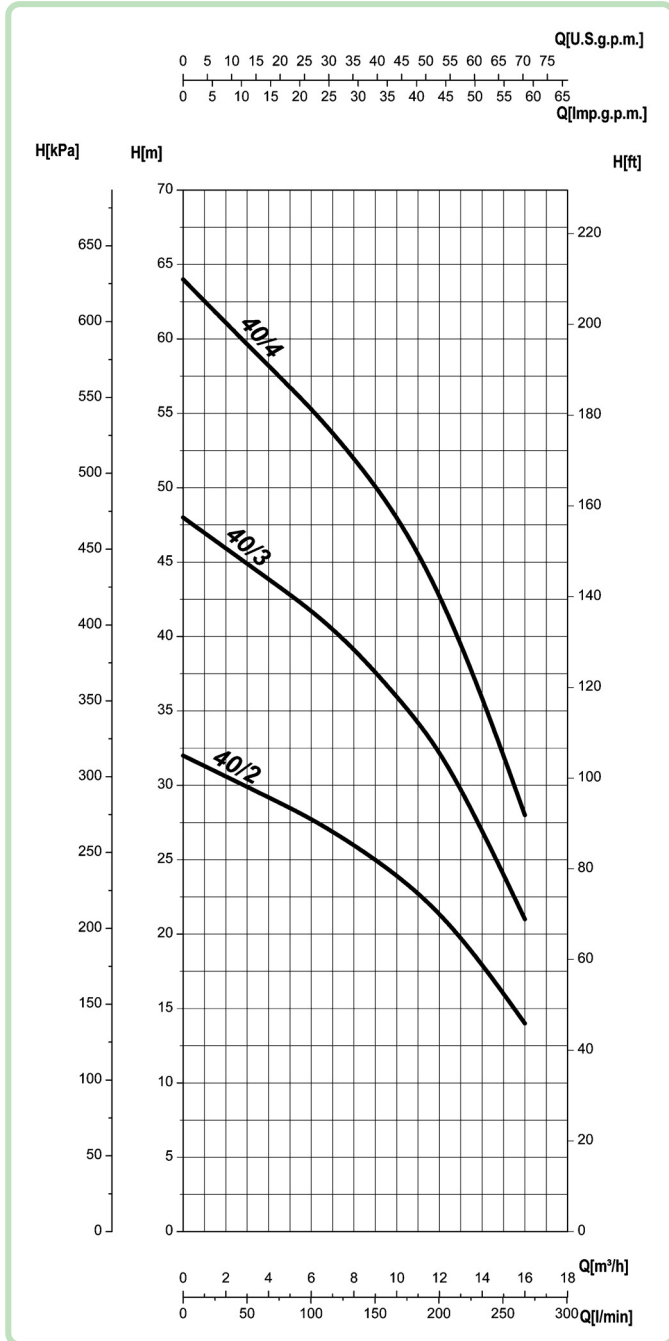

**• CARATTERISTICHE IDRAULICHE • HYDRAULIC FEATURES • CARACTERISTICAS HIDRAULICAS • CARACTERISTIQUES HYDRAULIQUES**  
**• HYDRAULISCHE EIGENSCHAFTEN • CARACTERÍSTICAS HIDRÁULICAS • ГИДРАВЛИЧЕСКИЕ ХАРАКТЕРИСТИКИ**

60P	P <sub>2</sub>		Q	H (m)												
	60 Hz			U.S.g.p.m.	0	18	26,5	35,5	40	44	48,5	53	57,5	62	66	70,5
			m³/h	0	4	6	8	9	10	11	12	13	14	15	16	
			l/min	0	67	100	133	150	167	183	200	217	233	250	267	
40/2	1,1	1,5	H (m)	32	29	28	26	25,0	24	23	21,5	20	18	16	14	
40/3	1,5	2		48	43,5	42	39	37,5	36	34,5	32,5	30	27	24	21	
40/4	2,2	3		64	58	56	52	50	48	46	43	40	36	32	28	

UNI EN ISO 9906-A

# 60P50

60 Hz

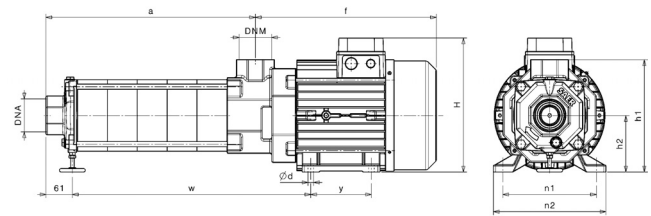
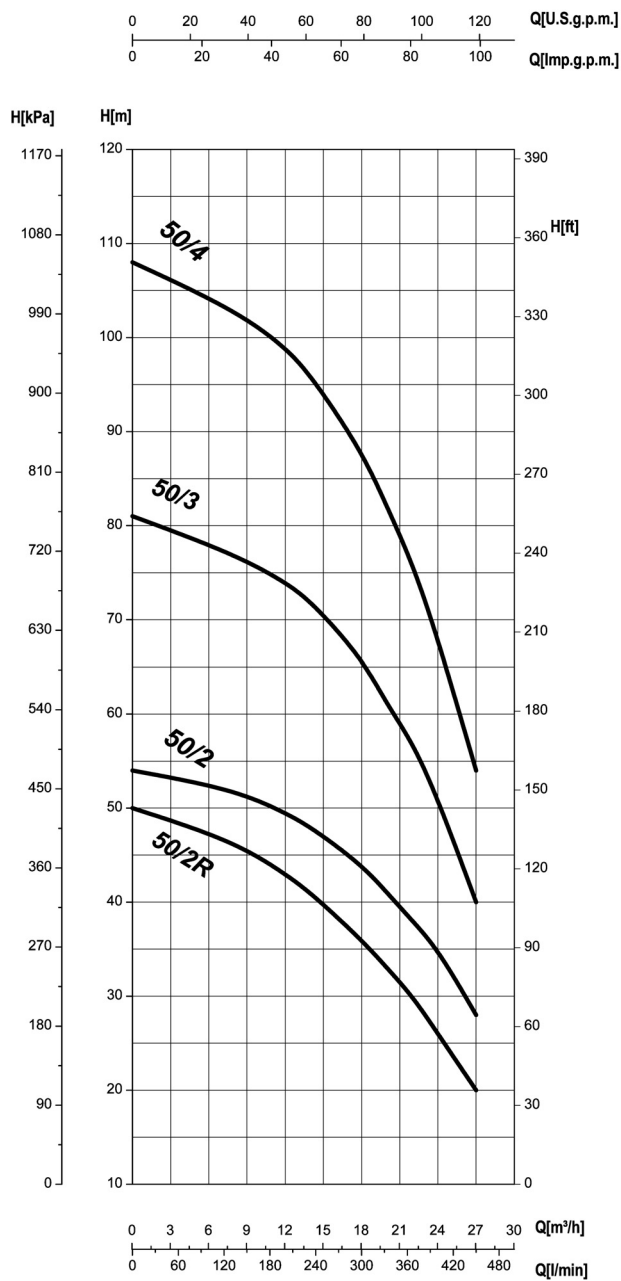

60P	a (mm)	f (mm)	w (mm)	H (mm)	Ød (mm)	h1 (mm)	h2 (mm)	n1 (mm)	n2 (mm)	y (mm)	DNA	DNM
50/2R	235	315	244	210	10	206	90	140	175	125	2"	2"
50/2	235	370	305	262	13	250	112	190	220	140	2"	2"
50/3	290	370	360	262	13	250	112	190	220	140	2"	2"
50/4	345	370	415	262	13	250	112	190	220	140	2"	2"

60P	P2		P1	460V 3~ In
	kW	HP	kW	A
50/2R	3	4	3,6	6
50/2	4	5,5	5,3	6,6
50/3	5,5	7,5	6,5	9,3
50/4	7,5	10	8,5	12,6

• CARATTERISTICHE IDRAULICHE • HYDRAULIC FEATURES • CARACTERISTICAS HIDRAULICAS • CARACTERISTIQUES HYDRAULIQUES  
• HYDRAULISCHE EIGENSCHAFTEN • CARACTERÍSTICAS HIDRÁULICAS • ГИДРАВЛИЧЕСКИЕ ХАРАКТЕРИСТИКИ

60P	P <sub>2</sub>		Q	U.S.g.p.m.	0	35	53	61	79	88	97	106	119
	60 Hz	kW		HP	m³/h	0	8	12	14	18	20	22	24
H (m)			kW		HP	l/min	0	133	200	233	300	333	367
	50/2R	3		4			H (m)	50	46	43	41	36	33
50/2	4	5,5	54	51	50	48		44	41	38	34	27	
50/3	5,5	7,5	81	77	75	72		66	61	57	51	40	
50/4	7,5	10	108	103	100	96		88	82	76	68	54	

UNI EN ISO 9906-A

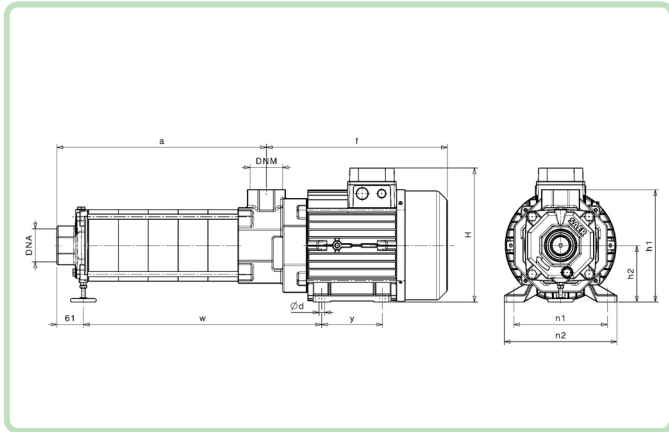

60P	a	f	w	H	Ød	h1	h2	n1	n2	y	DNA	DNM
	(mm)	(mm)	(mm)	(mm)	(mm)	(mm)	(mm)	(mm)	(mm)	(mm)		
65/2	270	370	318	262	13	250	112	180	220	140	2"1/2	2"1/2
65/3	346	420	413	310	13	260	132	216	260	140	2"1/2	2"1/2
65/4	415	502	482	310	13	260	132	216	260	178	2"1/2	2"1/2

60P	P2		P1	460V 3~ In	
	60 Hz	kW	HP	kW	A
65/2		7,5	10	8,9	15
65/3		9,2	12,5	10,6	19,6
65/4		13,5	18,3	15,4	22,5

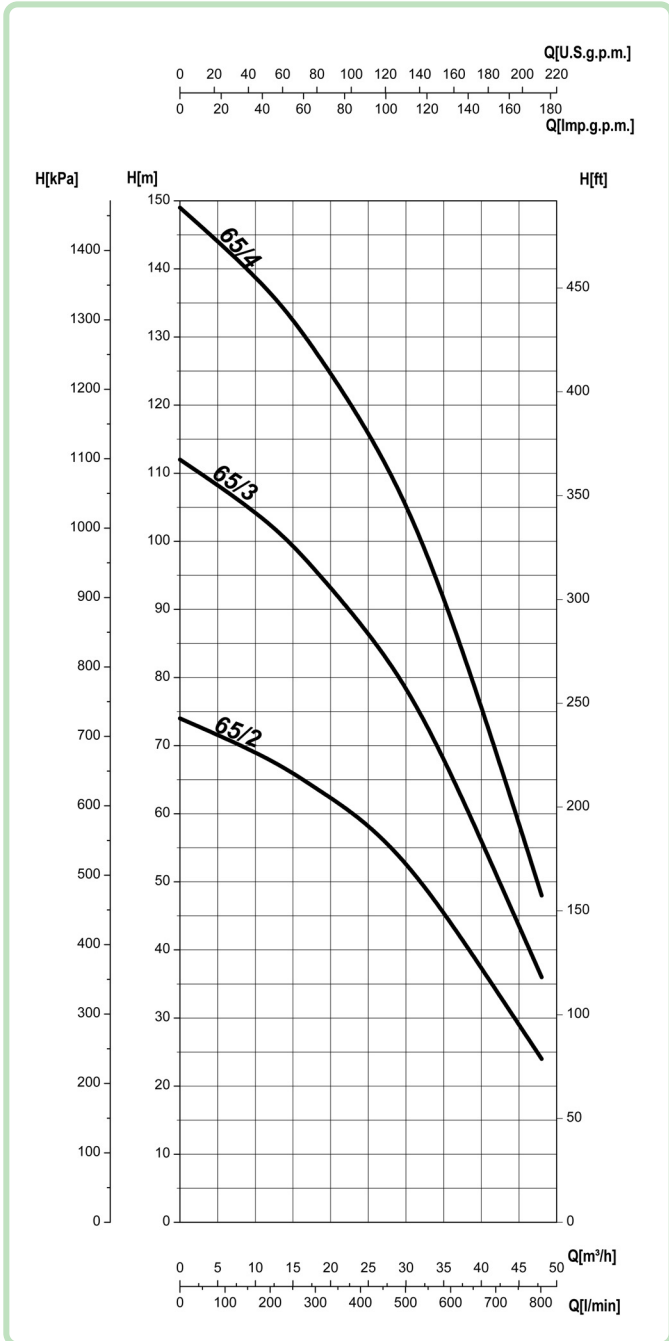

**• CARATTERISTICHE IDRAULICHE • HYDRAULIC FEATURES • CARACTERISTICAS HIDRAULICAS • CARACTERISTIQUES HYDRAULIQUES**  
**• HYDRAULISCHE EIGENSCHAFTEN • CARACTERÍSTICAS HIDRÁULICAS • ГИДРАВЛИЧЕСКИЕ ХАРАКТЕРИСТИКИ**

60P	P <sub>2</sub>		Q	H (m)								
	60 Hz	kW		HP	U.S.g.p.m.	0	53	79	106	132	159	185
			m <sup>3</sup> /h	0	12	18	24	30	36	42	48	
			l/min	0	200	300	400	500	600	700	800	
65/2	7,5	10		74	68	64	60	53	44	34	24	
65/3	9,2	12,5		112	103	96	88	79	66	51	36	
65/4	13,5	18,3		149	137	128	118	106	89	69	48	

UNI EN ISO 9906-A

# COMPONENTI PRINCIPALI DELLE POMPE

## MAIN PARTS OF THE PUMPS • COMPONENTES PRINCIPALES DE LAS BOMBAS PRINCIPAUX COMPOSANTS DES POMPES • HAUPTBAUTEILE DER PUMPEN COMPONENTES PRINCIPAIS DAS BOMBAS • ГЛАВНЫЕ КОМПОНЕНТЫ НАСОСОВ

OP 32 - 32/R  
OP 40-40/R

Bocca di aspirazione Inlet • Boca de aspiracion Orifice d'aspiration • Saugstutzen Boca de aspiraçao Всасывающий патрубок	Ghisa Cast iron • Fundicion gris Fonte • Gusseisen Ferro fundido Чугун	EN-GJL-250
Diffusore Diffuser • Difusor Diffuseur • Diffusor Diffusor Сектор кожуха с диффузором	Acciaio inox Stainless steel • Acero inox Acier inox • Edelstahl Aço inox Нержавеющая сталь	AISI 304 (1.4301)
Girante Impeller • Impulsor Roue • Laufrad Turbina Рабочее колесо	Acciaio inox Stainless steel • Acero inox Acier inox • Edelstahl Aço inox Нержавеющая сталь	AISI 304 (1.4301)
Anello di usura Wear ring • Anillo de desgaste Bague d'usure • Verschleissring Anilha de desgaste Кольцо изнашивания	Resina Resin • Resina Résine • Harz Resina Смола	
Albero Shaft • Eje Arbre • Rotorwelle Veio rotor Вал ротора	Acciaio inox Stainless steel • Acero inox Acier inox • Edelstahl Aço inox Нержавеющая сталь	AISI 431 (1.4057)
Guarnizione Gasket • Empaquetadura Joint • Dichtung Embranque Уплотнение	Fibra naturale Natural fibre • Fibra natural Fibre naturelle • Naturfaser Fibra natural Натуральное волокно	
Bocca di mandata Outlet • Cuerpo de descarga Corp de refolement • Druckstutzen Corpo de saida Напорный патрубок	Ghisa Cast iron • Fundicion gris Fonte • Gusseisen Ferro fundido Чугун	EN-GJL-250
Tenuta meccanica Mechanical seal • Cierre mecanico Garniture mécanique • Mechanische Dichtung Vedacao mecanica Торцевое уплотнение	Ossido di Allumina-Grafite-EPDM Alumina oxide-Graphite-EPDM Oxido de alumina-grafito-EPDM Oxyde d'albumine-Graphite-EPDM Alluminiumoxyd-Graphite-EPDM Oxido de Alumina-Grafite-EPDM оксид алюминия – графит – EPDM	

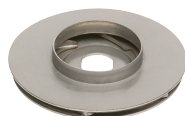

- Girante OP32-40 in acciaio INOX stampato
- Impeller OP32-40 in pressed stainless steel
- Impulsor OP32-40 en acero INOXIDABLE laminado
- Turbine OP32-40 en acier inox soudé
- Laufrad OP32-40 aus gestanztem rostfreiem Edelstahl
- Turbina OP32-40: aço inoxidável
- Рабочие колёса: штампованная нержавеющая сталь



- Diffusore OP32-40 in acciaio INOX stampato
- Diffuser OP32-40 in pressed stainless steel
- Difusor OP32-40 en acero INOXIDABLE laminado
- Diffuseur OP32-40 en acier INOX soudé
- Diffusor OP32-40 aus gestanztem rostfreiem Edelstahl
- Difusores OP32-40: aço inoxidável
- Диффузоры тампованная нержавеющая сталь



# COMPONENTI PRINCIPALI DELLE POMPE

MAIN PARTS OF THE PUMPS • COMPONENTES PRINCIPALES DE LAS BOMBAS  
 PRINCIPAUX COMPOSANTS DES POMPES • HAUPTBAUTEILE DER PUMPEN  
 COMPONENTES PRINCIPAIS DAS BOMBAS • ГЛАВНЫЕ КОМПОНЕНТЫ НАСОСОВ

	OP 50 OP 65	OPX 50 OPX 65
Bocca di aspirazione Inlet • Boca de aspiracion Orifice d'aspiration • Saugstutzen Boca de aspiraçao Всасывающий патрубок	Ghisa Cast iron • Fundicion gris Fonte • Gusseisen Ferro fundido Чугун	EN-GJL-250
Diffusore Diffuser • Difusor Diffuseur • Diffusor Diffusor Сектор кожуха с диффузором	Acciaio al carbonio microfuso Cast carbon steel Acero microfundido Acier au carbone de microfusion Praezisionsgusskohlenstoffstahl Aço microfundido Литая углеродистая сталь	G20Mn5 (1.6220)
Girante Impeller • Impulsor Roue • Laufrad Turbina Рабочее колесо	Acciaio al carbonio microfuso Cast carbon steel Acero microfundido Acier au carbone de microfusion Praezisionsgusskohlenstoffstahl Aço microfundido Литая углеродистая сталь	G20Mn5 (1.6220)
Anello di usura Wear ring • Anillo de desgaste Bague d'usure • Verschleissring Anilha de destaste Кольцо изнашивания		Bronzo Bronze • Bronze Bronze • Bronze Bronze Бронза
Albero Shaft • Eje Arbre • Rotorwelle Veio rotor Вал ротора	Acciaio inox Stainless steel • Acero inox Acier inox • Edelstahl Aço inox Нержавеющая сталь	AISI 431 (1.4057)
Anello OR O-Ring • Empaquetadura OR Joint OR • OR-Dichtung Anilha OR Кольцо OP		EPDM
Bocca di mandata Outlet • Cuerpo de descarga Corp de refoulement • Druckstutzen Corpo de saida Напорный патрубок	Ghisa Cast iron • Fundicion gris Fonte • Gusseisen Ferro fundido Чугун	EN-GJL-250
Tenuta meccanica Mechanical seal • Cierre mecanico Garniture mécanique • Mechanische Dichtung Vedacao mecanica Торцевое уплотнение		Ossido di Allumina-Grafite-EPDM Alumina oxide-Graphite-EPDM Oxido de alumina-grafito-EPDM Oxyde d'albumine-Graphite-EPDM Alluminiumoxyd-Graphite-EPDM Oxido de Alumina-Grafite-EPDM оксид алюминия – графит – EPDM

	<ul style="list-style-type: none"> <li>• Girante OP50 - 65 in acciaio al carbonio microfuso</li> <li>• Impeller OP50-65 in precision casted carbon steel</li> <li>• Impulsor OP50-65 en acero carbono microfundido</li> <li>• Turbine OP50-65 en acier au carbone de microfusion</li> <li>• Laufrad OP50 - 65 aus Praezisionsgusskohlenstoffstahl</li> <li>• Turbina OP50-65 aço microfundido</li> <li>• Рабочее колесо OP50 из литой углеродистой стали</li> </ul>		<ul style="list-style-type: none"> <li>• Diffusor OP50 - 65 in acciaio al carbonio microfuso</li> <li>• Diffuser OP50-65 in precision casted carbon steel</li> <li>• Difusor OP50-65 en acero carbono microfundido</li> <li>• Diffuseur OP50-65 en acier au carbone de microfusion</li> <li>• Diffusor OP50 - 65 aus Praezisionsgusskohlenstoffstahl</li> <li>• Difusores OP50-65 aço microfundido</li> <li>• Диффузор OP50 из литой углеродистой стали</li> </ul>
	<ul style="list-style-type: none"> <li>• Girante OP50-65 in acciaio INOX microfuso</li> <li>• Impeller OP50-65 in cast stainless steel</li> <li>• Impulsor OP50-65 en acero INOXIDABLE microfundido</li> <li>• Turbine OP50-65 en acier inox de microfusion</li> <li>• Laufrad OP50-65 aus Praezisionsgussedelstahl</li> <li>• Turbina OP50-65: aço inoxidável microfundido</li> <li>• Рабочие колёса из литой нержавеющей стали</li> </ul>		<ul style="list-style-type: none"> <li>• Diffusor OP50 - 65 in acciaio inox microfuso</li> <li>• Diffuser OP50-65 in precision casted stainless steel</li> <li>• Difusor OP50-65 en acero inox microfundido</li> <li>• Diffuseur OP50-65 en acier inox de microfusion</li> <li>• Diffusor OP50 - 65 aus Praezisionsgussedelstahl</li> <li>• Difusores OP50-65 aço inoxidável microfundido</li> <li>• Диффузор OP50 из литой углеродистой стали</li> </ul>

## OP

- Albero in unico pezzo in AISI431, supportato in tre punti
- Enbloc shaft in AISI 431 SS, supported in three points
- Eje en una unica pieza en acero AISI431, soportado en tres puntos
- Arbre, une seule pièce, en acier AISI431, supporté en trois points
- Die Welle aus einem Guss aus Edelstahl AISI 431, in drei Punkten gestützt
- Veio de um pedaço em aço inox AISI 431, sustentado em tres pontos
- Вал из цельного материала AISI431, с поддержкой в трёх точках



### OP32 | OP40

- Diffusori con anello di usura autocentrante
- Diffusers with self-centring wear wing
- Difusores con anillo de desgaste de autocentrado
- Diffuseurs avec bague d'usure
- Diffusor mit einem selbstzentrierenden Verschleißring
- Difusores com anilha de desgaste autofixante
- Диффузор с самоцентрирующимся кольцом изнашивания

- Tenuta meccanica: Grafite - Ossido di Allumina
- Mechanical seal: Graphite - Alumina oxide
- Cierre mecanico: Grafito - Oxido de Alumina
- Garniture mécanique: Oxide d'allumine - Graphite
- Mechanische Dichtung: Graphite - Aluminiumoxyd
- Sello mecánico: Grafito - Óxido de alúmina
- Торцевое уплотнение: графит – оксид алюминия

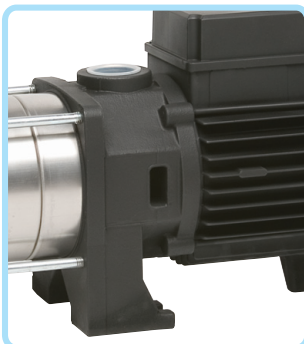

- Pompa e motore facilmente smontabili e riparabili
- Pump and motor easily disassembled and repairable
- Desmontaje y reparacion de bomba y motor muy simple
- Pompe et moteur qui peuvent être démontés et réparés avec facilité
- Pumpe und Motor, leicht zu demontieren und zu reparieren.
- Bomba e Motor facilmente desmontavel e reparavel.
- Насос и двигатель легко отсоединяются для проведения ревизии и ремонта

# ESEMPI DI INSTALLAZIONE

EXAMPLE OF INSTALLATION • EJEMPLOS DE INSTALACION  
EXEMPLES D'INSTALLATION • INSTALLATIONSBEISPIELE  
EXEMPLOS DE INSTALAÇÃO • Примеры установки

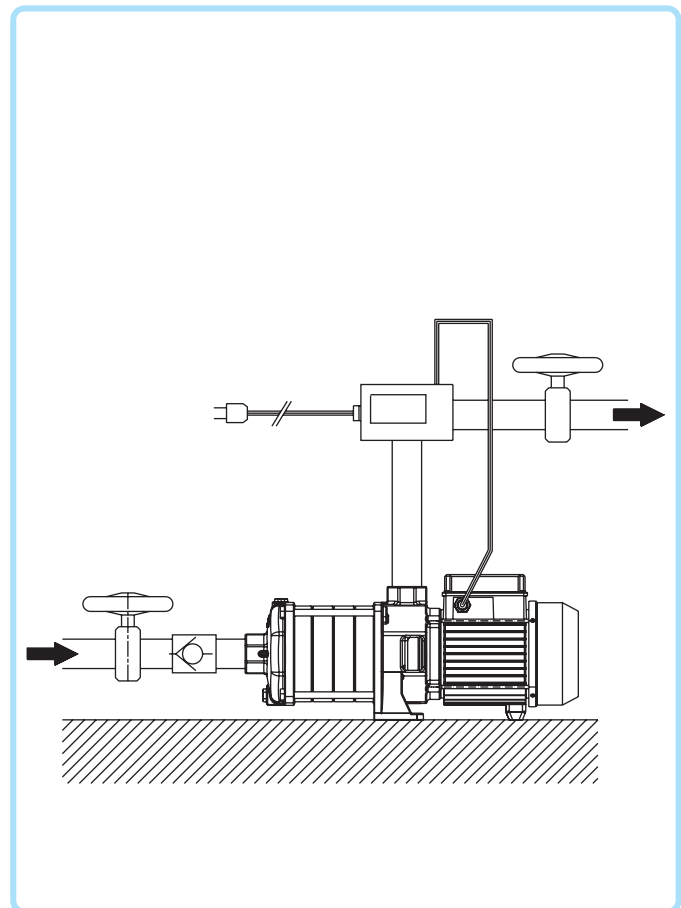
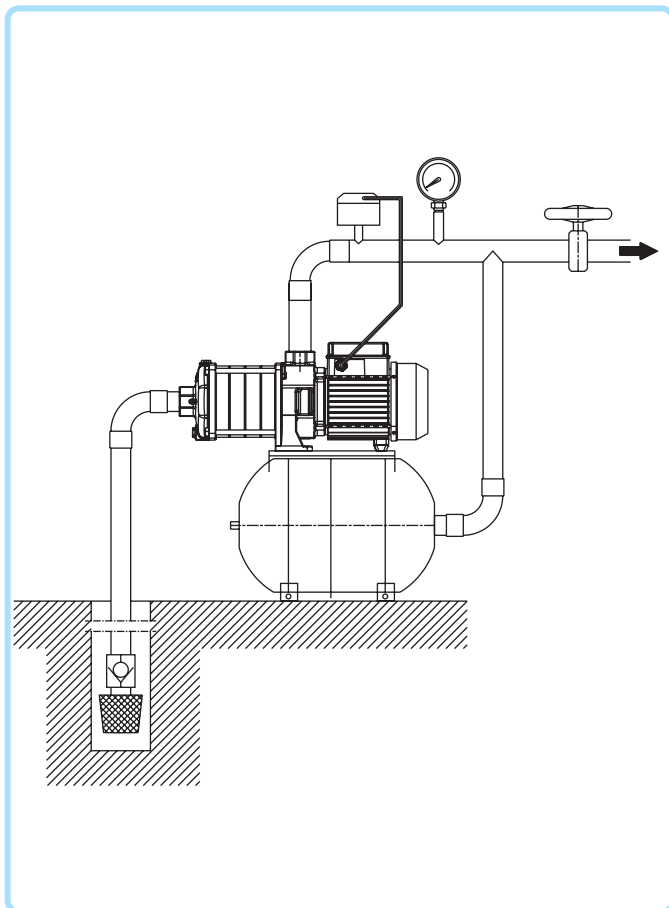
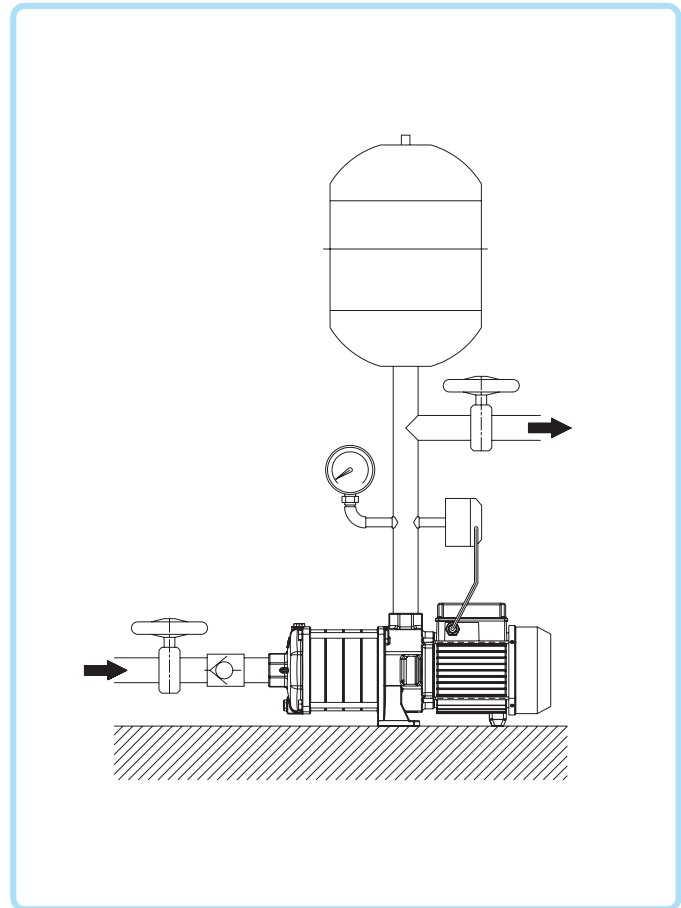
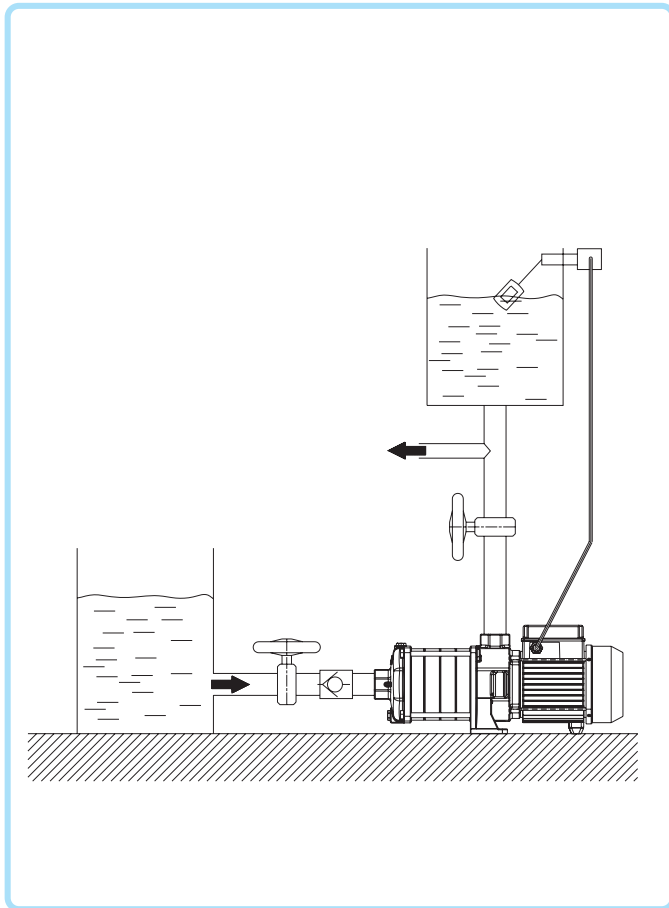

La ditta si riserva la facoltà di modificare senza preavviso i dati riportati in questo catalogo.  
Saer can alter without notifications the data mentioned in this catalogue.  
Saer se reserva el derecho de modificar los datos indicados en este catalogo sin previo aviso.  
Saer se réserve le droit de modifier sans préavis les données techniques dans ce catalogue.  
Das Unternehmen behält sich das Recht vor, die in dem Katalog vorhandenen Daten ohne Benachrichtigung zu ändern.  
Saer reserva o direito de modificar os dados indicados neste catálogo sem aviso prévio.  
**Компания оставляет за собой право без предупреждения корректировать  
данные содержащиеся в данном каталоге.**

Prestazioni e tolleranze secondo UNI EN ISO 9906 - Appendice A  
Performances and tolerances according to UNI EN ISO 9906 - Attachment A  
Prestaciones y tolerancias de acuerdo con UNI EN ISO 9906 - Parrafo A  
Performances et tolérances conformes aux normes UNI EN ISO 9906 - Annexe A  
Leistungen und Abweichungen gemäß UNI EN ISO 9906 - Anhang A  
Dados de rendição e tolerâncias de acordo com UNI EN ISO 9906 - Parágrafo A  
Эксплуатационные показатели соответствуют нормам UNI EN ISO 9906 - Дополнение A

**SAER<sup>®</sup>**  
**ELETTROPOMPE**

**SAER ELETTROPOMPE S.p.A.**

Via Circonvallazione, 22 • 42016 Guastalla (RE) Italy

Tel. 0522.83.09.41 r. a. • Fax 0522.82.69.48

e-mail: [info@saer.it](mailto:info@saer.it) - <http://www.saerelettropompe.com>

